

EPSON®

EPSON STYLUS® COLOR

1520

User's Guide



Printed on recycled paper with at least 10% post-consumer content.

All rights reserved. No part of this publication may be reproduced, stored in a retrieval system, or transmitted in any form or by any means, electronic, mechanical, photocopying, recording, or otherwise, without the prior written permission of SEIKO EPSON CORPORATION. The information contained herein is designed only for use with this EPSON printer. EPSON is not responsible for any use of this information as applied to other printers.

Neither SEIKO EPSON CORPORATION nor its affiliates shall be liable to the purchaser of this product or third parties for damages, losses, costs, or expenses incurred by purchaser or third parties as a result of: accident, misuse, or abuse of this product or unauthorized modifications, repairs, or alterations to this product, or (excluding the U.S.) failure to strictly comply with SEIKO EPSON CORPORATION's operating and maintenance instructions.

SEIKO EPSON CORPORATION shall not be liable for any damages or problems arising from the use of any options or any consumable products other than those designated as Original EPSON Products or EPSON Approved Products by SEIKO EPSON CORPORATION.

EPSON, EPSON Stylus, and ESC/P are registered trademarks and ESC/P 2 is a trademark of SEIKO EPSON CORPORATION.

General Notice: Other product names used herein are for identification purposes only and may be trademarks of their respective owners. EPSON disclaims any and all rights in those marks.

The ENERGY STAR emblem does not represent EPA endorsement of any product or service.

FCC Compliance Statement For United States Users

This equipment has been tested and found to comply with the limits for a Class B digital device, pursuant to Part 15 of the FCC Rules. These limits are designed to provide reasonable protection against harmful interference in a residential installation. This equipment generates, uses, and can radiate radio frequency energy and, if not installed and used in accordance with the instructions, may cause harmful interference to radio or television reception. However, there is no guarantee that interference will not occur in a particular installation. If this equipment does cause interference to radio and television reception, which can be determined by turning the equipment off and on, the user is encouraged to try to correct the interference by one or more of the following measures.

- Reorient or relocate the receiving antenna.
- Increase the separation between the equipment and receiver.
- Connect the equipment into an outlet on a circuit different from that to which the receiver is connected.
- Consult the dealer or an experienced radio/TV technician for help.

WARNING

The connection of a non-shielded equipment interface cable to this equipment will invalidate the FCC Certification of this device and may cause interference levels which exceed the limits established by the FCC for this equipment. It is the responsibility of the user to obtain and use a shielded equipment interface cable with this device. If this equipment has more than one interface connector, do not leave cables connected to unused interfaces. Changes or modifications not expressly approved by the manufacturer could void the user's authority to operate the equipment.

For Canadian Users

This Class B digital apparatus meets all requirements of the Canadian Interference-Causing Equipment Regulations.

Cet appareil numérique de la classe B respecte toutes les exigences du Règlement sur le matériel brouilleur du Canada.

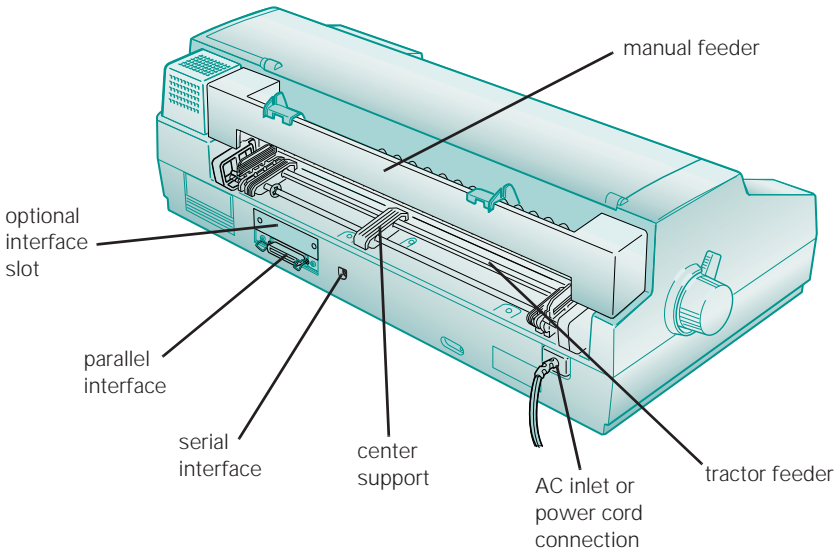
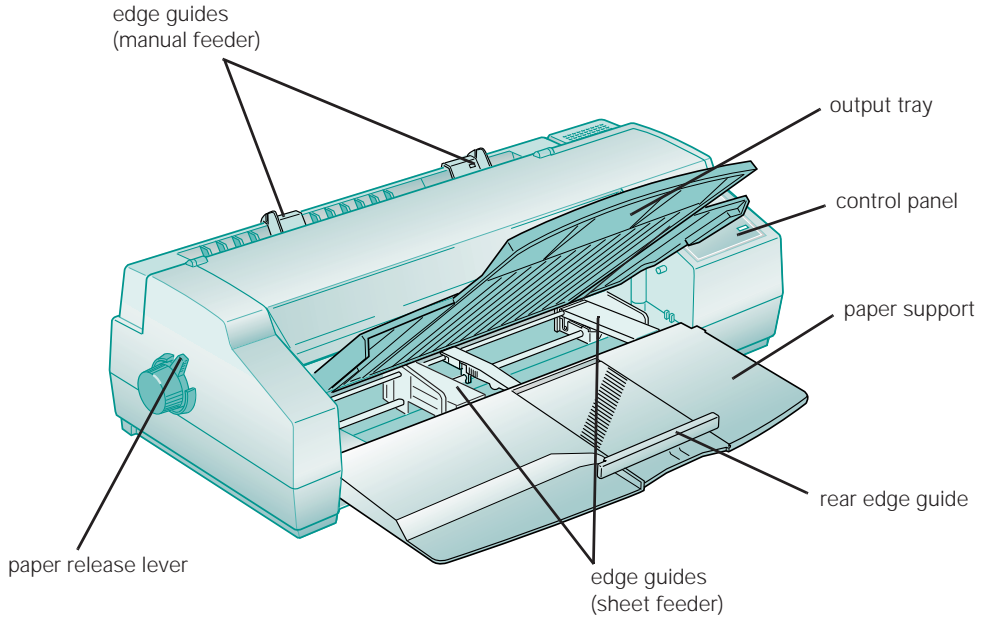

Contents

Introduction

| | |
|-------------------------------------|---|
| PC System Requirements | 2 |
| Macintosh System Requirements | 2 |
| How To Use Your Manuals | 3 |
| Warnings, Cautions, Notes, and Tips | 4 |
| Where To Get Help | 5 |
| Electronic Support Services | 5 |
| ENERGY STAR Compliance | 7 |
| Energy-saving Tips | 7 |
| Important Safety Instructions | 7 |

1 Basic Printing

| | |
|---|------|
| Printing from Windows | 1-1 |
| Setting Printer Options from Windows Applications | 1-2 |
| Setting Default Printer Options | 1-5 |
| Checking Printer Status | 1-7 |
| Printing from a Macintosh | 1-9 |
| Using Online Help | 1-11 |
| Accessing Help from Windows Applications | 1-11 |
| Accessing Help from Windows 95 | 1-12 |
| Accessing Help from Windows 3.1 | 1-12 |
| Accessing Help from Windows NT 4.0 | 1-12 |
| Accessing Help from Windows NT 3.51 | 1-12 |
| Accessing Help from Macintosh Applications | 1-12 |
| What To Do When the Printer Lights Come On | 1-13 |

2 *Custom Printing*

| | |
|---|------|
| Using Predefined Advanced Settings | 2-1 |
| Customizing Print Quality and Special Effects | 2-4 |
| Customizing Color Settings | 2-7 |
| Using ColorSync on the Macintosh | 2-10 |
| Saving Custom Settings | 2-11 |
| Deleting Custom Settings | 2-12 |
| Redefining Custom Settings | 2-13 |

3 *Printing on Special Media*

| | |
|---|------|
| Using Special Media Types | 3-2 |
| Media Loading and Software Setting Guidelines | 3-3 |
| Additional Media Loading Guidelines | 3-5 |
| Printing on Single Sheets | 3-6 |
| Loading Paper in the Built-in Sheet Feeder | 3-6 |
| Loading Paper in the Manual Feeder | 3-11 |
| Printing on Continuous Paper | 3-14 |
| Removing Continuous Paper | 3-18 |
| Using the Micro Adjust Buttons | 3-20 |
| Adjusting the Loading Position | 3-20 |
| Adjusting the Tear-off Position | 3-21 |
| Switching Between Continuous and Single-sheet Paper | 3-21 |
| Printing a Banner or Other Roll Paper Project | 3-22 |
| Loading Roll Paper | 3-22 |
| Printing a Banner from Windows | 3-27 |
| Printing a Banner from a Macintosh | 3-29 |
| Removing a Printed Banner | 3-30 |
| Printing a Backlit Display | 3-33 |
| Loading Back Light Film | 3-33 |
| Printing a Backlit Display from Windows | 3-34 |
| Printing a Backlit Display on a Macintosh | 3-35 |

4 *Managing Print Jobs and Network Printing*

| | |
|---|------|
| Managing Print Jobs with Windows 95 or 3.1 | 4-1 |
| Using the Spool Manager | 4-2 |
| Using the Status Monitor | 4-4 |
| Managing Print Jobs with Windows NT | 4-5 |
| Managing Print Jobs on a Macintosh | 4-6 |
| Using EPSON Monitor2 | 4-6 |
| Using the Macintosh Status Monitor | 4-7 |
| Network Printing on a PC | 4-9 |
| Connecting to the Printer on Windows NT 4.0 Systems | 4-9 |
| Connecting to the Printer on Windows NT 3.51 Systems | 4-10 |
| Using the Printer Software's Built-in Network Support | 4-11 |
| Network Printing on a Macintosh | 4-13 |
| Assigning a Name to the Printer | 4-14 |
| Setting Up the Printer for AppleTalk | 4-14 |

5 *Using Your Printer with DOS*

| | |
|---|------|
| Selecting Printer Software for DOS | 5-1 |
| Changing Printer Settings with Default-Setting Mode | 5-3 |
| Entering Default-Setting Mode | 5-3 |
| List of Default-Setting Options | 5-5 |
| Maintaining the Printer | 5-7 |
| Aligning the Print Heads with a DOS Utility | 5-7 |
| Selecting Character Tables | 5-8 |
| International Character Sets | 5-16 |
| Characters Available with the ESC (^ Command | 5-17 |

| | |
|-----------------------------------|------|
| Using Printer Commands | 5-17 |
| ESC/P 2 Control Codes | 5-18 |
| IBM XL24E Emulation Control Codes | 5-19 |

6 *Maintenance and Transportation*

| | |
|---|------|
| Cleaning the Print Heads | 6-1 |
| Using the Head Cleaning Utility | 6-2 |
| Using the Control Panel | 6-3 |
| Examining the Nozzle Check Pattern | 6-4 |
| Replacing an Ink Cartridge | 6-4 |
| Removing and Installing an Ink Cartridge | 6-5 |
| Printing in Black Ink with an Empty Color Cartridge | 6-7 |
| Aligning the Print Heads | 6-8 |
| Using the Print Head Alignment Utility | 6-8 |
| Using the Control Panel | 6-9 |
| Cleaning the Printer | 6-10 |
| Transporting the Printer | 6-10 |

7 *Troubleshooting*

| | |
|---|------|
| Diagnosing Problems | 7-1 |
| Running a Self Test | 7-2 |
| Printing a Hex Dump | 7-3 |
| Improving Print Quality | 7-4 |
| Solving Printing Problems | 7-8 |
| Fixing Paper Problems | 7-13 |
| Solving Miscellaneous Printout Problems | 7-16 |

A Using Optional Interfaces

| | |
|-------------------------------------|-----|
| Using Macintosh Interface Boards | A-2 |
| Using the PC Serial Interface Board | A-2 |
| Installing Optional Interfaces | A-2 |

B Using EPSON Plot!

| | |
|---------------------------|-----|
| Installing EPSON Plot! | B-1 |
| Printing with EPSON Plot! | B-2 |

C Specifications

| | |
|------------------|-----|
| Printing | C-1 |
| Paper | C-3 |
| Ink Cartridges | C-5 |
| Mechanical | C-6 |
| Electrical | C-6 |
| Environmental | C-6 |
| Safety Approvals | C-7 |
| Interfaces | C-7 |

Glossary

Index

Introduction



Note:

Also included are the EPSON Plot! program and EPSON's protected mode Autodesk® Device Interface (ADI)® plotter driver.

EPSON Plot! lets you print HPGL or HPGL/2 plot files on your printer. See Appendix B for details.

The ADI plotter driver lets you use your printer with AutoCAD® 386 (DOS Extender) releases 10 and higher that support ADI plotter drivers. See the README file on the ADI plotter driver diskette or printer software CD-ROM for more information.

Your EPSON Stylus® COLOR 1520 printer is the ideal output device for business communication pieces—such as presentations, signs, banners, maps, color comps, checkplots, iron-on transfers, and backlit displays—or any project you create. Using resolutions up to 1440 × 720 dpi (dots per inch), you get amazingly realistic photographic images, vivid color graphics, superb grayscale images, and razor-sharp black printing for crisp text and detailed line art.

With its large format print capabilities and versatile, built-in paper feeding options, the EPSON Stylus COLOR 1520 lets you print on virtually any media, of almost any size, including single sheets, continuous fold paper, and roll paper. You can even switch between printing on continuous paper and single sheets by flipping a lever.

The printer software for Microsoft® Windows® and Apple® Macintosh® computers provides advanced color management, with adjustable levels of brightness, contrast, saturation, and ink colors. Support for ColorSync™ 2.01 and Windows 95 ICM ensures printouts that closely match the colors on your monitor. You can also perform many printer maintenance procedures right from your computer, such as cleaning and aligning the print heads. And EPSON's extensive online help can guide you through printer operations in real time.

With standard parallel and high-speed serial ports and optional network connectivity, setting up your printer is fast and easy. EPSON's specially formulated, quick-drying ink and wide variety of ink jet media give you the best quality output and offer the most flexibility for getting the results you want.

PC System Requirements

To use your printer and its software with a PC, your system should have:

- An IBM® compatible PC with at least a 386/25 MHz or faster processor (486/25 MHz or faster for Windows NT)
- DOS, Windows 95, Windows 3.1x, Windows for Workgroups 3.11, Windows NT™ 4.0, or Windows NT 3.51
- At least 16MB of RAM
- At least 20MB of free hard disk space for storing images (50MB or more is recommended)
- VGA, Super VGA, or better display adapter and monitor
- Double-speed CD-ROM drive (quad-speed or faster recommended) for installing the printer software from the CD-ROM
- A shielded, twisted-pair parallel cable (6 to 10 feet long) to connect your computer to the printer; the cable must have a D-SUB, 25-pin, male connector for your computer and a 36-pin, Centronics® compatible connector for the printer.

For PC network interface options and the additional system requirements they may have, see Appendix A.

Macintosh System Requirements

To use your printer and its software with a Macintosh, your system should have:

- Any Macintosh or Power Macintosh model except the Macintosh +, Macintosh 512, or PowerBook™ 100
- System 7.1 or later
- At least 8MB of built-in RAM (16MB or more is recommended)

- ▶ Double-speed CD-ROM drive (quad-speed or faster recommended) for installing the printer software from the CD-ROM
- ▶ At least 20MB of free hard disk space for storing images (40MB or more is recommended)
- ▶ VGA, Super VGA, or better display adapter and monitor
- ▶ Standard Apple System Peripheral-8 serial cable or equivalent (RS-422, 8-pin mini DIN male/male)

For Macintosh network interface options and the additional system requirements they may have, see Appendix A.

How To Use Your Manuals

To set up your printer and install your printer software, see the *Quick Setup* booklet. This *User's Guide* contains the following information:

Chapter 1, “Basic Printing,” gives step-by-step instructions for everyday printing with Windows or Macintosh.

Chapter 2, “Custom Printing,” tells you how to print special projects with custom settings for print quality, special effects, and color management.

Chapter 3, “Printing on Special Media,” gives guidelines for selecting the right paper or other media for your print job and instructions for loading it in your printer.

Chapter 4, “Managing Print Jobs and Network Printing,” explains how to manage print jobs, check printer status, and set up your system for network printing.

Chapter 5, “Using Your Printer with DOS,” tells you how to use your printer with DOS applications, including selecting printer software for DOS, changing printer settings using default-setting mode, aligning the print heads, selecting character tables, and using printer commands.

Chapter 6, “Maintenance and Transportation,” gives instructions for replacing ink cartridges, cleaning and aligning the print heads, and cleaning and transporting the printer.

Chapter 7, “Troubleshooting,” provides solutions for any printing problems you may have.

Appendix A, “Using Optional Interfaces,” lists the optional interface boards and gives instructions for installing and using them.

Appendix B, “Using EPSON Plot!,” gives instructions on installing and using the EPSON Plot! program to print HPGL or HPGL/2 plotter files on your printer.

Appendix C, “Specifications,” provides the technical details on your printer, ink cartridges, and EPSON media.

A Glossary and an Index are included at the end of the book.

Warnings, Cautions, Notes, and Tips

You’ll find this information throughout your manual:



Warnings must be followed carefully to avoid bodily injury.



Cautions must be observed to avoid damage to your equipment.



Notes contain important information about your printer.



Tips contain additional hints for great printing.

Where To Get Help

EPSON provides customer support and service through a network of authorized EPSON Customer Care Centers. Dial (800) 922-8911 for the nearest location or the following services:

- FaxAdvice access to EPSON's technical information library
- Literature on current and new products
- The location of your nearest Authorized EPSON Reseller or Customer Care Center
- Technical information on the installation, configuration, and operation of EPSON products
- Customer relations

For answers to commonly asked questions about EPSON products 24 hours a day, seven days a week, call EPSON Sound Advice at (800) 442-2110.

You can purchase ink cartridges, paper, manuals, accessories, and parts from EPSON Accessories at (800) 873-7766 (U.S. sales only). In Canada, please call (800) 873-7766 for dealer referral.

If you need help using software with an EPSON product, see the documentation for that program for technical support information.

Electronic Support Services

You can access helpful tips, specifications, DIP switch or jumper settings, drivers, FAQs, sample files, application notes, and EPSON product bulletins 24 hours a day, seven days a week, using a modem and one of the online services below.

World Wide Web

From the Internet, you can reach EPSON's Home Page at <http://www.epson.com>.

EPSON Download Service

You can call the EPSON Download Service at (800) 442-2007. Set your communications software to 8 data bits, 1 stop bit, no parity. Modem speed can be up to 28.8 Kbps.

EPSON FaxAdvice Service

You can access EPSON's technical information library by calling (800) 442-2110 and selecting the appropriate phone option. You must provide a return fax number to use FaxAdvice.

EPSON Forum on CompuServe

Members of CompuServe[®] can type GO EPSON at the menu prompt to reach CompuServe's Epson America Forum. As an owner of an EPSON product, you are eligible for a free introductory CompuServe membership, which entitles you to an introductory credit and your own user ID and password. To take advantage of this offer in the U.S. or Canada, call (800) 848-8199 and ask for representative #529.



ENERGY STAR Compliance

As an ENERGY STAR Partner, EPSON has determined that this product meets the ENERGY STAR guidelines for energy efficiency.

The EPA ENERGY STAR Office Equipment program is a voluntary partnership with the computer and office equipment industry to promote the introduction of energy-efficient personal computers, monitors, printers, fax machines, and copiers in an effort to reduce air pollution caused by power generation.

Energy-saving Tips

Here are a few tips you can use to be even more energy-wise:

- If your monitor isn't ENERGY STAR compliant, turn it off when you're not using it.
- Turn off your computer, printer, and monitor each day when you are done using them.
- Use the print preview option in your software so you can catch errors before you print something.
- Send e-mail rather than distributing memos. Not only is this faster, but you'll save paper and storage space too.

Important Safety Instructions

Before using your printer, read the following safety instructions to make sure you use the printer safely and effectively.

- Turn off and unplug the printer before cleaning. Clean with a damp cloth only. Do not spill liquid on the printer.
- Do not place the printer on an unstable surface or near a radiator or heating vent.

- Do not block or cover the openings in the printer's cabinet or insert objects through the slots.
- Use only the type of power source indicated on the printer's label.
- Connect all equipment to properly grounded power outlets. Avoid using outlets on the same circuit as photocopiers or air control systems that regularly switch on and off.
- Place the printer near a wall outlet where the plug can be easily unplugged.

Placez l'imprimante près d'une prise de contact où la fiche peut être débranchée facilement.

- Do not let the power cord become damaged or frayed.
- If you use an extension cord with the printer, make sure the total ampere rating of the devices plugged into the extension cord does not exceed the cord's ampere rating. Also, make sure the total of all devices plugged into the wall outlet does not exceed 15 amperes.
- Except as specifically explained in this *User's Guide*, do not attempt to service the printer yourself.
- Unplug the printer and refer servicing to qualified service personnel under the following conditions:

If the power cord or plug is damaged; if liquid has entered the printer; if the printer has been dropped or the cabinet damaged; if the printer does not operate normally or exhibits a distinct change in performance. Adjust only those controls that are covered by the operating instructions.

Even if you are familiar with other types of printers, be sure to read through the following list of precautions before operating your ink jet printer:

- ▶ Do not put your hand inside the printer or touch the print heads during printing.
- ▶ Under normal circumstances, ink will not come out of the cartridges. If it does get on your skin, wash it off with soap and water. If it gets in your eyes, flush them immediately with water.
- ▶ Keep ink cartridges out of the reach of children.
- ▶ Do not dismantle the ink cartridges or try to refill them. This could result in damage to the print head.
- ▶ Once you install an ink cartridge, do not open the clamp or remove the cartridge except to replace it with a new one. The cartridge may become unusable otherwise.
- ▶ Install the ink cartridge immediately after you remove it from its package. Leaving the cartridge unpacked for a long time before use may result in reduced print quality.
- ▶ Do not use an ink cartridge beyond the date printed on the cartridge carton. For best results, use up the ink cartridges within six months of installing them.
- ▶ Do not shake an ink cartridge; this can cause leakage.
- ▶ Always turn the printer off using the  Operate button. When this button is pressed, the Operate light flashes briefly then goes out. Do not unplug the printer or turn off the power to the outlet until the Operate light is off.
- ▶ Before transporting the printer, make sure the print head is capped in the far right position and the ink cartridges are in place.
- ▶ If you use a printer stand, make sure it keeps the printer level and can hold up to 66 lb (30 kg). Secure the printer cables to a leg on the stand so they don't interfere with paper feeding.

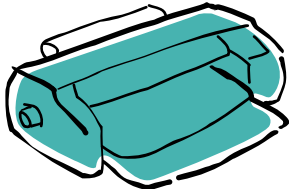

1

Basic Printing



Note:

If you print from DOS applications, see Chapter 5 for instructions on using your printer with DOS.

For instructions on printing HPGL or HPGL/2 plot files, see Appendix B.

It's easy to print all your color and monochrome (black ink) documents with your EPSON Stylus COLOR 1520. First you have to set up your printer and install the software following the instructions in the *Quick Setup* booklet. Then read this chapter to find out about the following:

- Printing from Windows
- Printing from a Macintosh
- Using online help
- What to do when the printer lights come on

Printing from Windows

When you want to print from a Windows application, you choose Print from the File menu. You can then choose which pages to print, the number of copies, and other options from your application's Print dialog box. When you click a button in the Print dialog box, you can select additional settings using your printer software, such as whether you want to use color or black ink.

The following sections tell you how to do the following:

- Set printer software options from Windows applications
- Change the default printer software settings
- Check your printer's status while you print



Note:
The settings you select through your Windows application usually apply only until you exit that application. Then the driver settings may return to the driver's default values or the Windows default values selected as described on page 1-5.



For more information about printer settings, click the Help button. With Windows 95 and Windows NT, you can right-click any item on the screen and then click What's This?

Setting Printer Options from Windows Applications

This section describes the options you'll need to set for all your everyday printouts. See Chapter 2 for information about advanced settings for special print jobs.

Follow these steps to check printer settings from your word processor or other Windows software:

1. Choose Print or Print Setup from the File menu.

If you choose Print, you first see your application's Print dialog box containing the settings you change most often, including the number of copies and the pages you want printed.

If you choose Print Setup, you first see a list of printers to choose from.

2. Make sure your EPSON Stylus COLOR 1520 printer is selected, and then click the Printer, Setup, Properties, or Options button. (You may have to click a series of these buttons, depending on the program you're printing with.) You see the printer software's dialog box:



3. If you don't see the dialog box shown in step 2, click the Main tab.
4. Make sure the Mode option is set to Automatic so the printer software can determine the best settings according to the Media Type and Ink settings you make. This is the easiest way to get good printing results for all kinds of documents, on all types of paper.
5. Choose the Media Type you want to print on from the following list (you may need to scroll through the list). If you are not sure which setting to select for your media, refer to the table on page 3-3.



For printing at the highest resolution (SuperFine quality at 1440 dpi), you need to use one of the photo quality media, the back light film, or the canvas cloth. For the best printing at any resolution, always use EPSON media.

- ▶ Plain paper
- ▶ 360 dpi Ink Jet Paper
- ▶ Photo Quality Ink Jet Paper
- ▶ Photo Quality Glossy Paper
- ▶ Photo Quality Glossy Film
- ▶ Ink Jet Transparencies
- ▶ Ink Jet Back Light Film
- ▶ Ink Jet Canvas Cloth

The type of media you choose determines the Print Quality setting (resolution) you can use.

6. Choose Color or Black ink. If you're printing black text or a draft, or if you want colors to print as varying shades of gray, select Black for faster printing.
7. Set the slider to Quality or Speed. This lets you choose between high resolution printing or faster printing on the media you're using. (The slider is not available for certain media types and may not set the highest available resolution.)
8. Click the Paper tab and choose your paper feeding source.



Note:
Whenever you change the Paper Source, Paper Size, or Orientation settings, check the printer illustration in the dialog box to see how your document will print.

If you load your paper long edge first, select a landscape paper size, such as Letter (Landscape), and then select your print orientation so the printer knows which way you loaded the paper.

Keep in mind that some application software may have paper size and orientation settings that override your printer software settings.

To cancel your changes and exit the printer software, click the Cancel button at the bottom of the menu at any time.

The default Paper Source is Auto Sheet Feeder, for the built-in sheet feeder at the front of your printer. (For instructions on printing with other feeders, see Chapter 3.)

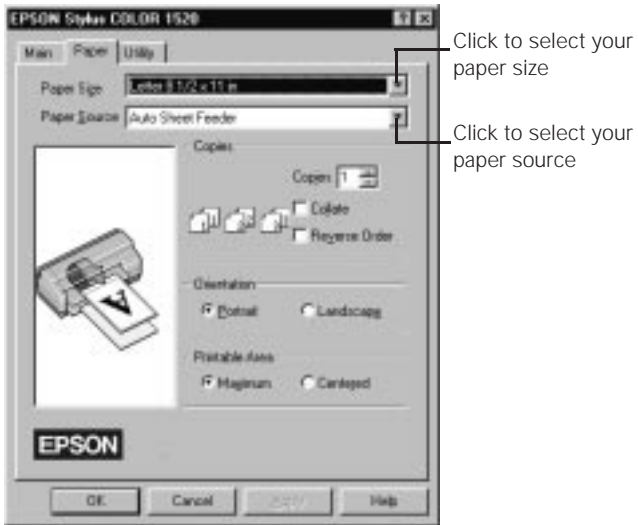

9. Choose the Paper Size setting, number of copies, collation options, orientation, and printable area. (Your software application may let you control some of these settings. With Windows NT, there are no collation options.)
10. Click the Main tab and check the Current Settings box on the bottom of the menu to see if the other settings are correct for your document. If you need to adjust them, use Advanced mode as described in Chapter 2.
11. Click OK when you're finished checking your settings. The dialog box closes.
12. In your application's printing dialog box, click Close, OK, or Print. (You may need to click a series of these buttons, depending on the program you're printing with.)

While you're printing, the EPSON Despooler dialog box appears, showing the printing progress and the status of your printer. (With Windows NT, you don't see the Despooler.) See "Checking Printer Status" on page 1-7 for more information.



Note:
Some application settings override printer software settings (such as Paper Size or Orientation), so it's a good idea to check the settings in your application before you print.

Setting Default Printer Options

When you change printer settings through a Windows application (as described above), the settings apply only to the application you're using. If you want to adjust the default settings for **all** your Windows applications, you can access the printer software through the Windows 95 or NT printer properties, or the Windows 3.1 Control Panel.

Make sure all your software applications are closed before you start. If not, you'll have to close and then reopen them to have the new default settings take effect.

Setting Default Options in Windows 95

1. Click Start, point to Settings, and then point to Printers.
2. Right-click the EPSON Stylus COLOR 1520 icon.
3. Select Properties, then click the Main tab. You see the Main printer settings dialog box.
4. Change the settings as described on page 1-2 and click OK. Any changes you make become the default settings for all your applications and documents.

Setting Default Options in Windows 3.1

1. Double-click the Control Panel icon in the Main group.
2. Double-click the Printers icon.
3. Select EPSON Stylus COLOR 1520 from the list of printers and click Setup. You see the Main printer settings dialog box.
4. Change the settings as described on page 1-2 and click OK. Any changes you make become the default settings for all your applications and documents.



Note:
You can access the default Windows NT printer software settings only if you have the appropriate network access privileges, such as Administrator or Power User.

Setting Default Options in Windows NT 4.0

1. Click Start, point to Settings, and then point to Printers.
2. Click the EPSON Stylus COLOR 1520 icon.
3. Open the File menu and select Document Defaults. You see the Main printer settings dialog box.
4. Change the settings as described on page 1-2 and click OK. Any changes you make become the default settings for all your applications and documents.

Setting Default Options in Windows NT 3.51

1. Double-click the Control Panel icon in the Main group.
2. Double-click the Printers icon.
3. Select the EPSON Stylus COLOR 1520 printer window, if necessary.
4. Open the Printer menu and select Properties.
5. Click Details, then click Job Defaults. You see the Main printer settings dialog box.
6. Change the settings as described on page 1-2 and click OK. Any changes you make become the default settings for all your applications and documents.

Checking Printer Status

While your document is printing, the EPSON Despooler dialog box appears on your screen. (With Windows NT you don't see the Despooler. See the next page for more information.)



If you don't want the Despooler dialog box to appear each time you print, you can turn it off. To do this, start Spool Manager, open the View menu, and select Show Despool Popup; the checkmark next to the option disappears.

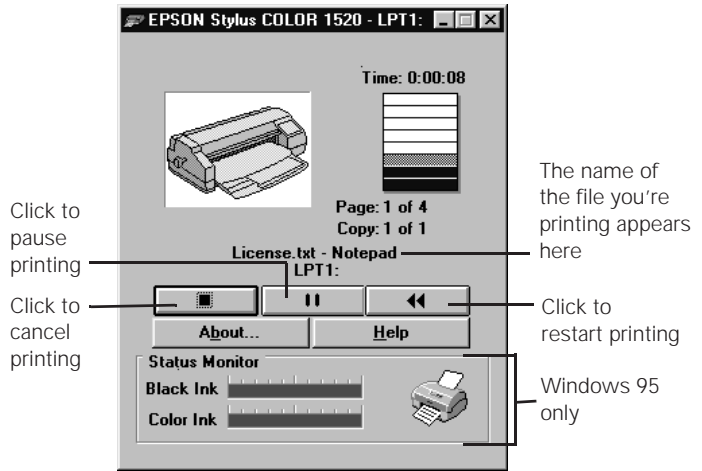







This dialog box shows the progress of your print job and the status of your printer. If you run out of paper, for example, the Despooler warns you.

You can use the buttons to cancel, pause, or restart your print job, if necessary. When the print job is finished, the Despooler dialog box disappears.



Note:
The Status Monitor appears only if you're using Windows 95 and you're not printing over a network.

The Status Monitor at the bottom of the dialog box shows how much ink is left in your printer, along with these status icons:

| | |
|---|--|
|  | Checking the printer status. |
|  | A printing error has occurred and your printer cannot print. Check your printer or see Chapter 7 for troubleshooting information. |
|  | The printer is ready to print. |
|  | The printer is currently printing. |
|  | The ink level is low or empty; check the Ink Out  or Ink Out  light on the control panel and replace the cartridge if necessary. |

Checking Printer Status with Windows NT

With Windows NT 4.0 servers and workstations, the messenger service alerts you to printer errors or lets you know when a print job is finished. If you have appropriate network access privileges or you're controlling printing from the server, you can also cancel, pause, or restart print jobs and set the sharing, security, scheduling, and port options. See your Windows NT 4.0 documentation for details.

You can check the status of your print job in Windows NT 3.51 using the Print Manager. Options in the Print Manager window let you pause, resume, or delete print jobs and handle the print queues on your system, depending on your network access privileges. See your Windows NT 3.51 documentation for instructions.

Printing from a Macintosh

When you print with a Macintosh, you need to check the printer software settings for each application you use. This section describes the settings you'll need to choose for all your everyday printouts. See Chapter 2 for information about advanced settings for special print jobs.



Note:

Whenever you change the Paper Source, Paper Size, or Orientation settings, check the printer illustration in the dialog box to see how your document will print.

If you load your paper long edge first, select a landscape paper size, such as Letter (Landscape), and then select your print orientation so the printer knows which way you loaded the paper.

Keep in mind that some application software may have paper size and orientation settings that override your printer software settings.

To cancel your changes and exit the software, click the Cancel button at any time.

1. Start the application you want to print from and create a document.
2. Choose Page Setup from the File menu. You see the Page Setup dialog box:

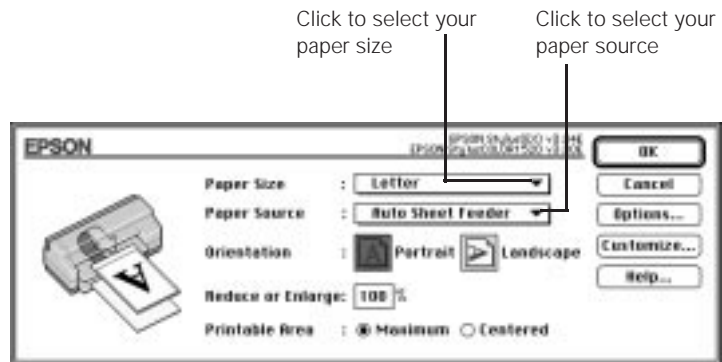

3. First choose your paper feeding source. The default Paper Source is Auto Sheet Feeder, for the built-in sheet feeder at the front of your printer. (For instructions on printing with the other feeders, see Chapter 3.)
4. After selecting your paper source, choose the Paper Size setting, orientation, reduction or enlargement, and printable area. (Your software application may let you control some of these settings.)
5. Click OK to close the Page Setup dialog box and continue.
6. Choose Print from the File menu or click the print icon in your application.

You see a dialog box like the following:

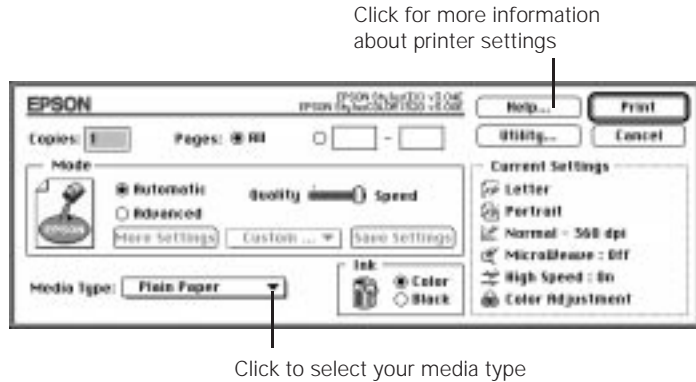

7. Choose the number of copies and indicate which pages you want to print.
8. Make sure the Mode option is set to Automatic so the printer software can determine the best settings according to the Media Type and Ink settings you make. This is the easiest way to get good printing results for all kinds of documents, on all types of paper.
9. Choose the Media Type you want to print on from the following list. If you are not sure which setting to select, refer to the table on page 3-3.
 - ▶ Plain Paper
 - ▶ 360 dpi Ink Jet Paper
 - ▶ Photo Quality Ink Jet Paper
 - ▶ Photo Quality Glossy Paper
 - ▶ Photo Quality Glossy Film
 - ▶ Ink Jet Transparencies
 - ▶ Ink Jet Back Light Film
 - ▶ Ink Jet Canvas Cloth



For printing at the highest resolution (SuperFine quality at 1440 dpi), you need to use one of the photo quality media, back light film, or canvas cloth. For the best printing at any resolution, always use EPSON media.

The type of media you choose determines the Print Quality setting (resolution) you can use.



Note:

On the Macintosh, printer settings are saved with your document, but you can't save them from one application to another. You'll have to check your settings each time you print from a new application. If you want to reuse settings, you can create document templates for your favorite applications.

A Power Macintosh Extension module called EPSON Stylus

PowerPlug was installed and enabled when you installed your Macintosh printer software. This extension accelerates the rendering and processing of all documents when you're using a Power Macintosh.

10. Choose Color or Black ink. If you are printing black text or a draft, or if you want colors to print as varying shades of gray, choose Black for faster printing.
11. Set the slider to Quality or Speed. This lets you choose between high resolution printing or faster printing on the media you're using. (The slider is not available for certain media types and may not set the highest available resolution.)

Once you've changed these basic settings, check the Current Settings box on the right side of the menu to see if the other settings are correct for your document. If you need to adjust them, use Advanced mode as described in Chapter 2.

12. Click Print when you're finished checking your settings.

If you chose background printing when you set up your printer, you can continue working while your document is printing. See "Using EPSON Monitor2" in Chapter 4.

Using Online Help

For complete information about using the printer software, you can easily access online help any time.

Accessing Help from Windows Applications

To access online help from your application, open the File menu and choose Print or Print Setup. Then click Printer, Setup, Options, or Properties; you may need to click a series of these buttons, depending on the software you're using. Click the Help button at the bottom of the dialog box for help related to the items on that dialog box. Then select a help topic.

You can also access online help when you're not using the software, as described below.



With Windows 95 and Windows NT you can get specific help related to any item in the menus by right-clicking the item and then clicking the What's This? prompt.

Accessing Help from Windows 95

Click the Start button, point to Programs, and Epson, and then click EPSON Stylus COLOR 1520 Help. For instructions on using help, read the online “Quick Guide to Using Help.”

Accessing Help from Windows 3.1

In Program Manager, open the EPSON group and click the EPSON Stylus COLOR 1520 Help icon. For instructions on using help, read the online “Quick Guide to Using Help.”

Accessing Help from Windows NT 4.0

Click the My Computer icon, then click the Printers icon. Right-click the EPSON Stylus COLOR 1520 icon and select Document Defaults from the menu. In the printer software dialog box, click the Help button. For instructions on using help, read the online “Quick Guide to Using Help.”

Accessing Help from Windows NT 3.51

Double-click the Control Panel icon in the Main group. Then double-click the Printers icon. Select the EPSON Stylus COLOR 1520 printer window, then open the Printer menu and select Properties. Click Details, then click Job Defaults. In the printer software dialog box, click the Help button. For instructions on using help, read the online “Quick Guide to Using Help.”

Accessing Help from Macintosh Applications

Choose Print from the File menu or click the print icon in your application. Click the Help button for help related to the items on that menu. To exit Help, click the OK button at the bottom of the Help screen.

What To Do When the Printer Lights Come On

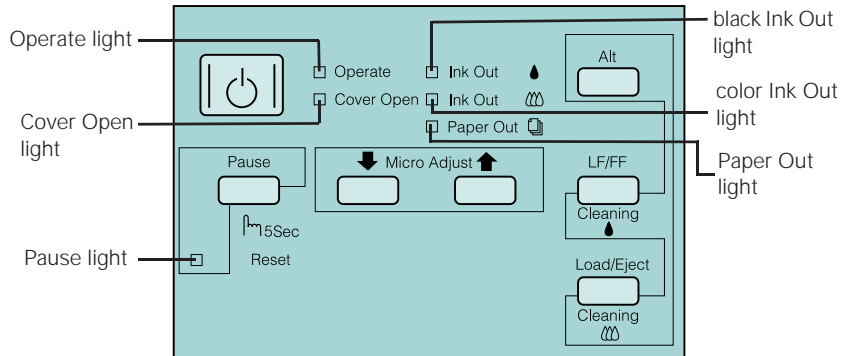

The lights on your printer's control panel show the printer's status and alert you to problems, such as paper jams or low ink.



Operate

The Operate light is on when the printer is on. When the Operate light *flashes*, the printer is receiving data. It may also flash with other lights during other operations or error conditions.

Paper Out

When the Paper Out light comes on, your paper ran out or is loaded incorrectly, or the paper release lever is set to the wrong position. Load paper, check the lever position (as described on page 3-6), and then press the Load/Eject button to turn off the light. If the Pause light is on, press the Pause button to turn it off.

When the Paper Out light *flashes*, you have a paper jam. Turn off the printer and gently pull out all jammed paper. Reload the paper, then press the Load/Eject button to turn off the light. If the Pause light is on, press the Pause button to turn it off. (See Chapter 7 for more information.)

| | |
|---|--|
| Ink Out  | When an Ink Out light <i>flashes</i> , your ink supply is low. Make sure you have a replacement cartridge. |
| Ink Out  | When an Ink Out light comes on, you need to replace the ink cartridge. See Chapter 6 for instructions. |

| | |
|-------|--|
| Pause | <p>When the Pause light is on, printing is paused. Press the Pause button to resume.</p> <p>When the Pause light <i>flashes</i>, your printer is charging ink, cleaning the print heads, or performing another operation. See Chapter 6 for details.</p> <p>If you need to reset the printer's memory, hold down the Pause button for 5 seconds.</p> |
|-------|--|

| | |
|------------|---|
| Cover Open | When the Cover Open light comes on, the printer's cover is open and printing is paused. Close the cover. If the Pause light is on, press the Pause button to turn it off and resume printing. |
|------------|---|

| | |
|----------------|---|
| All the lights | When all the lights <i>flash</i> , your printer may have an internal error. See Chapter 7 for more information. |
|----------------|---|



2

Custom Printing

When you want to print presentation graphics, photographs, or other special projects, you can use the custom settings in your EPSON Stylus COLOR 1520 software. You can choose predefined settings or adjust individual options like brightness, contrast, saturation, and halftoning. For professional-quality color accuracy, you can use Image Color Matching (ICM) with Windows 95 or ColorSync on the Macintosh.



Note:
For instructions on printing HPGL or HPGL/2 plot files, see Appendix B.

This chapter includes the following information:

- ▶ Using predefined advanced settings
- ▶ Customizing print quality and special effects
- ▶ Customizing color settings
- ▶ Using ColorSync on the Macintosh
- ▶ Saving custom settings

Using Predefined Advanced Settings

Predefined settings provide an easy way to fine-tune your printer's operation for special projects. Follow these steps to print with predefined settings:

1. Create your document, image, or project in your application software.

2. Access the Main printer settings dialog box as described on page 1-2 (Windows) or page 1-9 (Macintosh).

You see one of the following dialog boxes:

Click **Advanced**, then click here to see a list of project types



Note:
When you use advanced settings, the Quality/Speed slider disappears.



Windows



Macintosh

Click **Advanced**, then click here to see a list of project types

3. Select Color or Black Ink.



Note:
Always choose your Ink setting before you select a project setting from the Customs Settings list.

Selecting Video/Digital Camera, ICM, or ColorSync automatically sets the Ink option to Color.



Note:
See Chapter 3 for information about using special media.

4. Click Advanced, and then Custom Settings. You see a list of project types.
5. Follow these guidelines to choose the right setting for your project:
 - **Photo**
For printing scanned photographs. Increases contrast in the image.
 - **Text/Graph**
For printing graphics-intensive documents like presentation pages with charts and graphs. Intensifies colors and lightens the midtones and highlights.
 - **Video/Digital Camera (not available with Windows NT)**
For images captured from a digital camera or video. Increases color brightness and makes the image sharper.
 - **Economy**
For rough drafts of text only, on plain paper. Saves ink.
 - **ICM (Windows 95 only)**
Automatically adjusts printout colors to closely match the colors on your screen.
 - **ColorSync (Macintosh only)**
Automatically adjusts printout colors to closely match the colors on your screen. For more information, see page 2-10.
6. Choose the Media Type you want to print on. (If you are not sure which setting to select, refer to the table on page 3-3.) The available media may be limited by the project you choose.
7. Select the correct Paper Source, Paper Size, and other options for the media and feeder you're using. See page 1-3 (Windows) or page 1-9 (Macintosh) for instructions.

Custom Printing



Note:

If you're printing with Windows NT 3.51, follow the steps in the next section to check an additional print option described on page 2-7.



Note:

After you customize your print settings for a special project, you can save them as a group. Then you can reuse them whenever you print a similar project. See page 2-11 for instructions.

8. Check the Current Settings box on the bottom of the menu to see if the other settings are correct for your document. If they're correct, click OK or Print. (If you're using Windows, click any other buttons that your application uses for printing.)

If the predefined settings are not quite what you want, follow the steps in the next section to change them.

Customizing Print Quality and Special Effects

If you need maximum control over your project, or you want to experiment with special effects, you can adjust individual settings in your printer software. Follow these steps:

1. Create your document, image, or project in your application software.
2. Access the Main printer settings dialog box as described on page 1-2 (Windows) or page 1-9 (Macintosh).
3. Click Advanced, and then click More Settings. You see the More Settings dialog box:

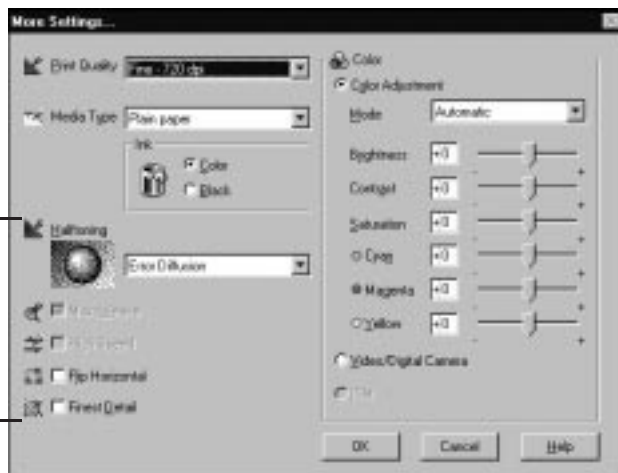

Some of these options are automatically set or disabled by other settings you choose

Windows

Some of these options are automatically set or disabled by other settings you choose

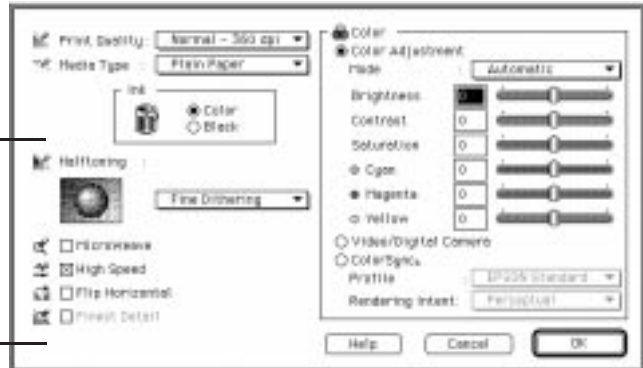

Macintosh



Note:

The Print Quality is selected automatically depending on the current Media Type. If you choose a Print Quality setting that is not appropriate for your media, the driver changes the Media Type setting. Be sure to check both of these settings to make sure they are correct for the media you loaded.

4. Choose one of the following Print Quality options:
 - ▶ **Economy**
For low-resolution rough drafts on plain paper. Saves ink.
 - ▶ **Normal - 360 dpi**
For most documents on plain paper, transparencies, or 360 dpi Ink Jet or Banner paper.
 - ▶ **Fine - 720 dpi**
For high-resolution output. Works best on photo quality media, back light film, or canvas cloth.
 - ▶ **SuperFine - 1440 dpi**
For the highest-resolution output on photo quality media, back light film, or canvas cloth only.
5. Choose the Media Type setting you want to use, following the guidelines on page 3-3.
6. Select Color or Black ink.

Custom Printing



Note:
In Automatic mode, the Halftoning setting is selected based on the data in your print job. In Advanced mode, Halftoning is preselected for each document type setting. The No Halftoning option is available only when you select Black as the Ink setting.



If vertical lines in your printout are misaligned when you use the High Speed setting, you may need to align the print heads. See Chapter 6 for instructions.

7. Choose one of the following Halftoning options:
 - No Halftoning
For printing black text only.
 - Error Diffusion
For printing photographic or video/digital camera images. Blends each dot of color with the surrounding dots.
 - Fine Dithering, Coarse Dithering
For printing charts, graphs, and other images that require precise, solid areas of bright colors. Arranges dots in orderly patterns. Use Coarse for images with more shading and less detail. Use Fine for images with more detail and less shading.

8. Choose any of the following print options. Some of these settings are automatically selected or disabled by the Print Quality (resolution) and Media Type settings you chose.
 - MicroWeave
For improved print quality. Prints graphic data in finer increments to eliminate unwanted banding effects (light horizontal lines). Always use for color printing.
 - High Speed
For fast, bidirectional printing at lower quality.
 - Flip Horizontal
Prints a mirror image of your document. Use for printing with iron-on transfer paper or back light film so the image will appear correctly on your iron-on item or backlit display.
 - Finest Detail
For printing text, graphics, and line art with very sharp edges. Slows print speed and increases your system memory requirements.

- ▶ **Print Using a Temporary File (Windows NT 3.51 only)**
For increasing the speed that Windows NT 3.51 returns to your application by printing to a temporary print file. A separate application then sends the file to your printer. Turn this option off when printing complex documents or if parts of a printout are missing after printing with it turned on.
9. If you're ready to print, click OK and go to step 10. If you want to adjust your printer's color settings, see the next section.
 10. Click Save Settings if you want to save your custom settings as a group that you can reuse for special projects. See page 2-11 for instructions.
 11. Click OK (Windows) or Print (Macintosh). If you're using Windows, click any other buttons that your application uses for printing.

Customizing Color Settings

You can choose from several color adjustment modes or manually adjust brightness, contrast, saturation, and individual CMY (cyan, magenta, yellow) colors. For improved color accuracy, you can use Image Color Matching (ICM) under Windows 95 or ColorSync on the Macintosh.

Follow these steps to customize your color settings:

1. Access the More Settings dialog box as described on page 2-4. The color settings appear on the right side of the dialog box, as shown:

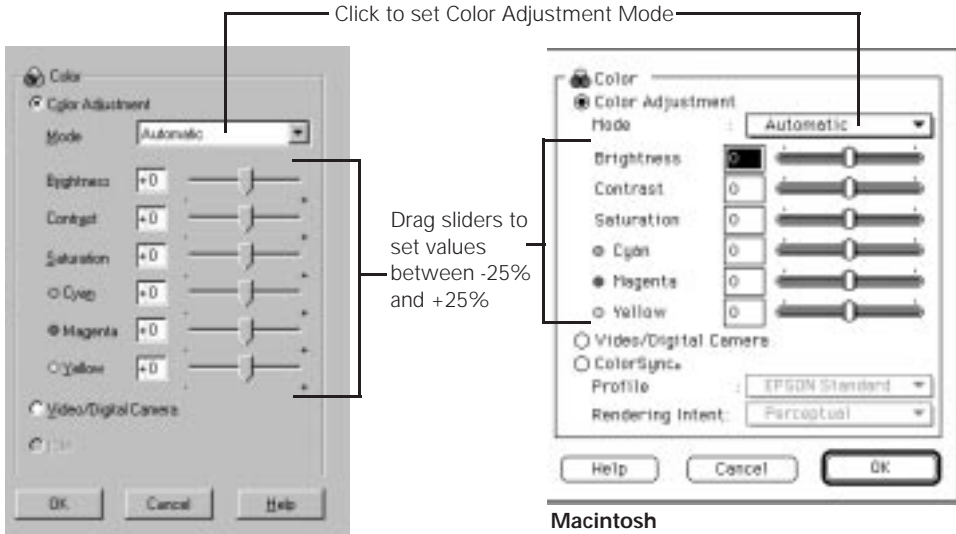

Windows

(ICM is available only for Windows 95)

2. Choose one of the following Color Adjustment Modes or choose another mode, as described in step 4:
 - **Automatic**
Analyzes the color information in your project and optimizes color correction accordingly.
 - **Photo-realistic**
For printing color photographs.
 - **Vivid**
For printing graphics-intensive documents like presentation pages with charts and graphs. Intensifies colors and lightens the midtones and highlights.

- ▶ No Color Adjustment (Windows NT 4.0 and Macintosh only)
With Windows NT 4.0, disables the color adjustment features of the printer software so you can adjust colors using your application. On a Macintosh, choose this mode only if you're using ColorSync.
3. If you want to change individual color characteristics, use the scroll bars to increase (drag right) or decrease (drag left) the settings listed below. (If you use one of the options described in step 4, you won't be able to specify individual color characteristics.)
- ▶ Brightness
Makes your image lighter or darker.
 - ▶ Contrast
Increases or decreases the difference between the bright or dark parts of an image.
 - ▶ Saturation
Makes colors more vivid or less vivid.
 - ▶ Cyan, Magenta, Yellow
Increases or decreases the amount of the three ink colors that combine to make a full-color picture. Use to fine-tune the color balance in your printout.
4. To fine-tune color correction for video/digital images or to closely match screen colors, choose one of these modes instead of a Color Adjustment Mode:
- ▶ Video/Digital Camera (not available with Windows NT)
Use for printing images captured from a digital camera or video. Increases contrast and saturation and makes the image sharper.
 - ▶ ICM (Windows 95 only)
Automatically adjusts printout colors to closely match colors on the screen.



Note:

When you choose Video/Digital Camera, ICM, or ColorSync, the individual color characteristics described in step 3 are preset.

The availability of ICM depends on your Print Quality, Media Type, and Halftoning settings.

- ▶ **ColorSync (Macintosh only)**
Automatically adjusts printout colors to closely match colors on the screen. See “Using ColorSync on the Macintosh” below for instructions.
5. Click OK to return to the Main printer settings dialog box.
 6. Click Save Settings if you want to save your custom settings as a group that you can reuse for special projects. See page 2-11 for instructions.
 7. Click OK (Windows) or Print (Macintosh). If you’re using Windows, click any other buttons that your application uses for printing.

Using ColorSync on the Macintosh

Every device you use for viewing or producing colors—your monitor, scanner, and printer—uses a different color technology. That’s why it’s difficult to get printed colors to match the colors displayed on your monitor.

Each device has its own gamut, or range of colors, that it can reproduce. The Macintosh ColorSync system translates colors from one gamut to another so your monitor’s colors match your printer’s colors as closely as possible.

ColorSync uses profile information from each device—including your EPSON Stylus COLOR 1520—to achieve accurate color matching. First you set your monitor’s profile. Then you can use your printer software to specify the exact method of “gamut mapping” (color matching) you want to use. Follow these steps:

1. Open ColorSync System Profile under Control Panels on the Apple menu.
2. Click the Set Profile button.
3. Select your monitor from the list, and then click Select.



Note:
The EPSON Standard profile is custom-designed for your printer. If you use a scanner or other color imaging equipment, you may have other profiles available.

The Saturation and Colorimetric options are only available when you're using Fine - 720 dpi or SuperFine - 1440 dpi Print Quality.

4. Close ColorSync System Profile.
5. Open the application you want to print from.
6. Access the printing dialog box as described on page 1-9. Click Advanced and then click More Settings.
7. Click ColorSync on the right side of the dialog box.
8. For Profile, choose EPSON Standard.
9. Choose one of the following options for Rendering Intent:
 - Perceptual
For printing photographs. Adjusts the colors displayed on the monitor so they fit within the printer's gamut, but maintains the relationships between colors.
 - Saturation
For printing graphics-intensive documents like presentation pages with charts and graphs. Maintains the relative saturation of colors from one gamut to another.
 - Colorimetric
For matching colors as precisely as possible. Maintains colors that fall within the gamuts of the monitor and printer, but may lose some detail where the colors are outside the printer's density range.
10. Click OK, and then click Print.

Saving Custom Settings

After you've fine-tuned your printer settings for a special project, you can save them as a group with a unique name. Then you can select it the next time you print a similar project.

1. Customize your printer settings as described in this chapter.
2. Click the Save Settings button on the Main printer settings dialog box. (If the button is grayed out, select Advanced.)

Custom Printing



Note:
You can save up to 10
groups of settings.

If you change the Media Type or Ink setting when your customized setting is selected, the setting selected in the list changes to Custom Settings. To return to your customized setting, reselect it in the list. To redefine a customized setting, see page 2-13.

You see one of the following:



Windows

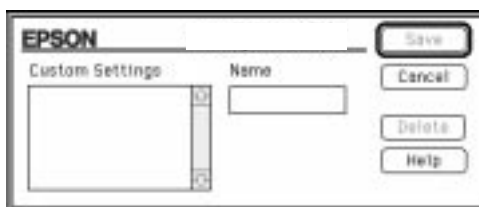

Macintosh

3. Type a unique name for your settings (up to 16 characters) and click the Save button.

The name you choose is now available on the Main printer settings dialog box when you click Advanced, and then Custom Settings.

Deleting Custom Settings

If you no longer need a customized setting, follow these steps to delete it:

1. Select Advanced mode.
2. Click Save Settings.
3. Select the name of your custom setting group in the Custom Settings box, and click Delete. (You cannot delete any of the predefined document types.)

Redefining Custom Settings

To change the options in a customized setting group but keep the same name for it, follow these steps:

1. Select Advanced mode.
2. Select the name of the custom setting group you want to redefine in the Custom Settings list.
3. Change the printer settings as necessary. (If you change the Media Type and Ink setting, the custom setting group name disappears from the list momentarily.)
4. Click Save Settings.
5. Select the name of the custom setting group you're redefining in the Custom Settings box.
6. If you're using Windows, click Save. You see the Save As dialog box. Click OK to save your redefined settings. (Click Cancel to cancel your changes.)

On a Macintosh, click the Redefine button. Then click Replace at the confirmation dialog box to save your redefined settings. (Click Cancel to cancel your changes.)



3

Printing on Special Media

Your EPSON Stylus COLOR 1520 lets you print on just about any kind of paper you want to use. You can get great results printing on plain paper, letterhead, and envelopes. But you'll get the best results with EPSON's specially coated ink jet paper. You can choose from a variety of EPSON media, ranging from glossy paper and transparencies to iron-on transfer paper and canvas cloth.

Your printer's versatile feeding options let you load media of almost any size or format, including single sheets, continuous paper, and roll paper for banners and signs. You can even load two types of paper at once, switching between them with the flip of a lever when you're ready to print on them.

This chapter covers the following:

- Using special media types
- Printing on single sheets
- Printing on continuous paper
- Adjusting the loading and tear-off positions
- Switching between continuous and single-sheet paper
- Printing a banner or other roll paper project
- Printing a backlit display

Using Special Media Types

The type of paper or other media you use can help determine the ultimate quality of your printed output. You can achieve good results with plain paper, but for better results, use EPSON media for EPSON ink jet printers because they provide the best surface for the ink used in your printer.

EPSON ink jet paper comes in a variety of types and sizes. To order, contact your dealer or call EPSON Accessories at (800) 873-7766 (U.S. sales only). In Canada, please call (800) 873-7766 for dealer referral.

| Media name | Size | Part number |
|-----------------------------------|--|---|
| EPSON 360 dpi Ink Jet Paper | Letter A4 Super A3/B | S041060 S041059 S041066 |
| EPSON High Quality Ink Jet Paper | Letter A4 | S041111 S041117 |
| EPSON Photo Quality Ink Jet Paper | Letter A4 Legal B Super A3/B A2 | S041062 S041061 S041067, S041048 S041070 S041069 S041079 |
| EPSON Photo Quality Glossy Paper | A4 Letter A2 Super A3/B | S041126 S041124 S041123 S041133 |
| EPSON Photo Quality Glossy Film | A4 Letter A6 B Super A3/B | S041071 S041072 S041107 S041075 S041074 |
| EPSON Ink Jet Transparencies | A4 Letter | S041063 S041064 |
| EPSON Photo Quality Ink Jet Cards | A6 8 × 10 | S041054 S041122 |
| EPSON Iron-On Transfer Paper | Letter Super A3/B | SE41001, SE41002 SE41003 |

| Media name | Size | Part number |
|--|---------------------------------------|--------------------|
| EPSON Photo Quality Self Adhesive Sheets | A4 | S041106 |
| EPSON Photo Quality Banner Paper | A2 × 15 m roll 16.5 inches × 49 ft | S041102 |
| EPSON Ink Jet Canvas Cloth | A2 × 3 m roll 16.5 inches × 9.8 ft | S041132 |
| EPSON Ink Jet Back Light Film | A3 A2 | S041131 S041130 |

Media Loading and Software Setting Guidelines

Whether you print on plain paper or special media, you need to load it according to the guidelines in the table below. You must also select the correct Media Type setting in your printer software to match the media you loaded. Also check the media loading guidelines following the table for more information.

| When you load media with this name . . . | Load a maximum of this many sheets in the built-in sheet feeder as described on page 3-6 . . . | Then select this Media Type setting in your printer software . . . |
|---|--|--|
| Plain paper (single sheets) | 100 letter size 30 Super A3/B size 30 A2 size | Plain paper |
| Continuous paper (plain or labels) | See "Printing on Continuous Paper" on page 3-14. | |
| Envelopes ¹ | 10 | |
| EPSON 360 dpi Ink Jet Paper | 70 letter size 30 legal size 30 Super A3/B size 30 A2 size | 360 dpi Ink Jet Paper |
| EPSON Special Coated Paper for 360 dpi Printing | | |
| EPSON High Quality Ink Jet Paper | 70 letter size 30 legal size 30 Super A3/B | Photo Quality Ink Jet Paper |
| EPSON Photo Quality Ink Jet Paper | 30 A2 size | |
| EPSON Special Coated Paper for 720 dpi Printing | | |

Printing on Special Media

| When you load media with this name . . . | Load a maximum of this many sheets in the built-in sheet feeder as described on page 3-6 . . . | Then select this Media Type setting in your printer software . . . |
|---|--|--|
| EPSON Photo Quality Ink Jet Cards | 30 cards ¹ | Photo Quality Ink Jet Paper |
| EPSON 720 dpi Index Cards | | |
| EPSON Photo Quality Self Adhesive Sheets | See "Loading Paper in the Manual Feeder" on page 3-11. | |
| EPSON Photo Quality Banner Paper | See "Loading Roll Paper" on page 3-22. | |
| EPSON Photo Quality Glossy Paper (use with support sheet) | 20 sheets | Photo Quality Glossy Paper |
| EPSON Photo Quality Glossy Film (use with support sheet) | 30 letter size ² 1 A2 size | Photo Quality Glossy Film |
| EPSON High Quality Glossy Paper (use with support sheet) | 30 letter size ² 1 A2 size | |
| EPSON Iron-On Transfer Paper ³ | 1 sheet | |
| EPSON Ink Jet Transparencies (use with support sheet) | 30 sheets | Ink Jet Transparencies |
| EPSON Ink Jet Back Light Film | See "Loading Back Light Film" on page 3-33. | Ink Jet Back Light Film |
| EPSON Ink Jet Canvas Cloth | See "Loading Roll Paper" on page 3-22. | Ink Jet Canvas Cloth |

¹ If you're printing from DOS, see Chapter 5 for printing instructions.

² With multiple sheets loaded, the minimum top margin is 1.2 inches (30 mm). For a smaller top margin or for ease in loading, load and print one sheet at a time with a support sheet beneath it.

³ Turn on the Flip Horizontal option to reverse your image before you print it—especially if it includes text—so the image will appear correctly when it's transferred. See Chapter 2 for instructions. After you print, follow the instructions that came with the paper to iron the image onto the shirt or other item.



Note:

If you don't see the Media Type option for your paper when you're using the printer software, change the Print Quality setting in the More Settings dialog box, select Automatic as the Mode setting, or change the predefined setting in the Custom Settings list on the Main menu. See Chapter 2 for instructions on selecting these settings.

Be sure to feed a cleaning sheet through the printer after using any package of special media that comes with the cleaning sheet so you don't experience feeding problems.

Additional Media Loading Guidelines

- In addition to the Media Type setting, remember to select the correct Paper Size for your media.
- Some special media have a cut corner you must position correctly; follow any instructions in the package. Always handle sheets by the edges; don't touch the printable side.
- Make sure labels are fully adhered to their backing sheet before you load them.
- When loading pre-printed paper, such as letterhead or forms, make sure the paper's top edge leads into the printer.
- Use ink jet papers within one year of purchase. Use glossy media and transparencies within six months. Return unused media to their original packages as soon as possible. See Appendix C for more media storage information.
- If your special media came with a cleaning sheet, be sure to feed it through the printer after you've finished using the package of paper. Peel off the instruction sheet; then position the cut corner of the cleaning sheet in the built-in sheet feeder as shown below. Press the Load/Eject button to feed it through the printer. Repeat this several times.

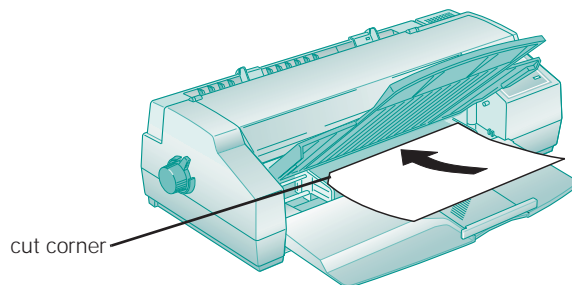

- See these sections for complete paper loading instructions:
 - See page 3-6 for sheet feeder instructions.
 - See page 3-11 for manual feeder instructions.
 - See page 3-14 for tractor feeder instructions.
 - See page 3-22 for roll feeder instructions.

Printing on Single Sheets

You can print on single sheets of paper up to 17 inches wide (432 mm) in your printer using the built-in sheet feeder or the manual feeder.

You'll probably use the built-in sheet feeder at the front of your printer for the size paper you use most often, such as letter- or legal-size sheets. Then you can use the manual feeder at the top of the printer for loading individual, large format sheets or roll paper using the optional Banner Paper Kit. (See page 3-22 for more information on the Banner Paper Kit.)

Follow the instructions in the sections below to load single sheets of paper from these feeders.



Note:
The maximum printable width is 13.6 inches (345 mm) on any size paper.

Loading Paper in the Built-in Sheet Feeder

You can load paper up to 17 inches wide (432 mm) in the built-in sheet feeder, but do not load the stack above the arrow mark on the right edge guide. Load legal-size or larger paper no more than halfway to the arrow mark.

If you load paper more than 14.3 inches (364 mm) wide, load a maximum of 30 sheets at a time, regardless of the paper type.

1. Turn on the printer, but don't send a print job before you load paper in the sheet feeder; always load paper first.
2. Set the paper release lever to the single sheet position (the single sheet icon appears beneath the lever handle).

single sheet icon

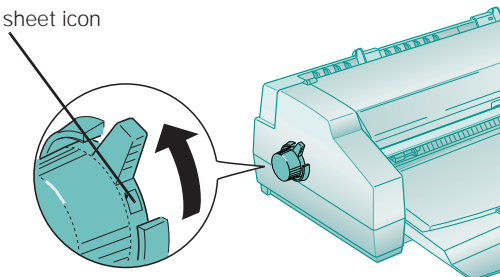

3. Open the printer cover and set the thickness lever to the 0 position when you print on plain paper, ink jet paper, transparencies, or transfer paper.

Set it to the + position when you print on envelopes, ink jet cards, or heavy paper.

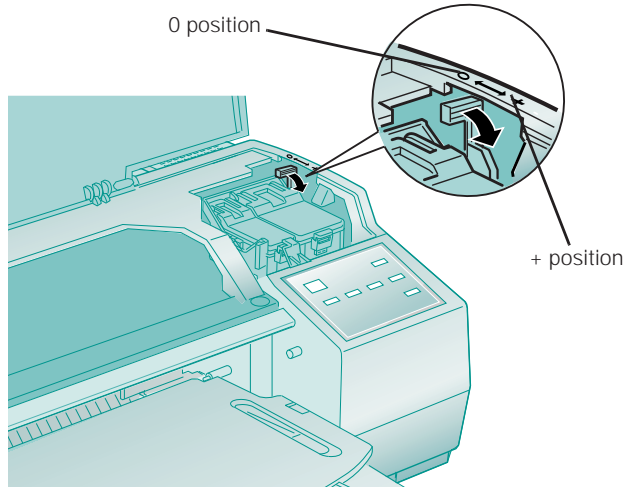

4. Lock the output tray in an upright position on the two upper posts.

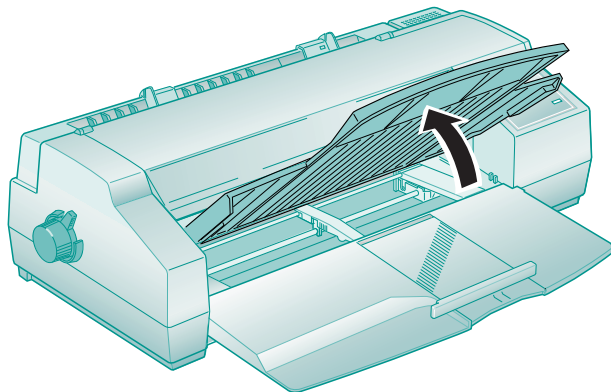

5. If you'll be printing on paper that is 14.3 inches (364 mm) wide or less, slide the **right** edge guide all the way **left** until it stops.

If the paper is more than 14.3 inches (364 mm) wide, slide the **right** edge guide all the way **right**.

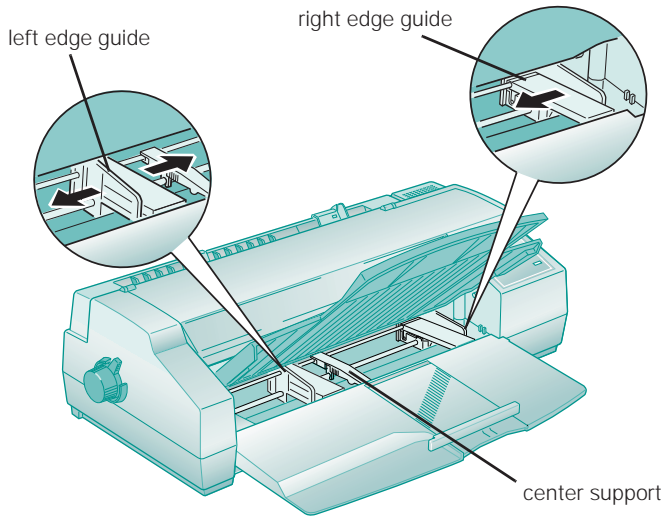

6. Slide the left edge guide to match the approximate width of your paper. Then move the center support midway between the two edge guides.
7. Pull out the rear paper support guide until it stops.

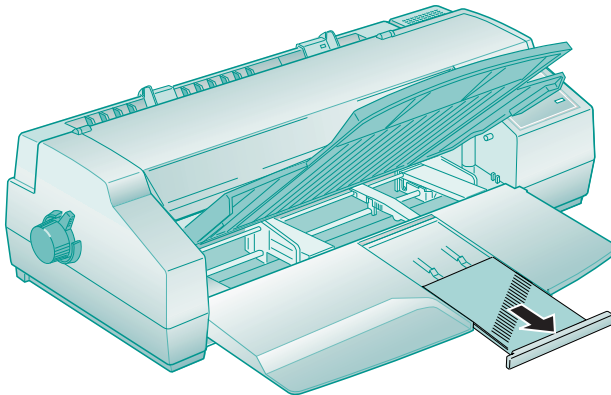

8. Fan your stack of paper and then even the edges.

9. Load a stack of paper with the printable side **face down** and slide it all the way into the feeder. Gently press the stack against the right edge guide. Then slide the left edge guide against the left side of the paper.

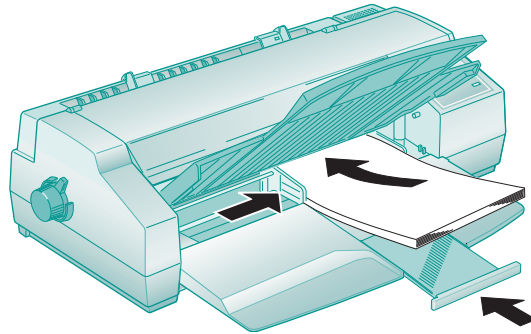

If you're loading paper that does not reach to the end of the rear paper support guide, slide the guide up against the edge of the paper. If your paper is long, let it lay over the edge of the paper support.

To load up to 10 envelopes, place them **face down** with the flap edge leading into the feeder. Then slide the left edge guide and the rear paper support guide against the edges of the envelopes.

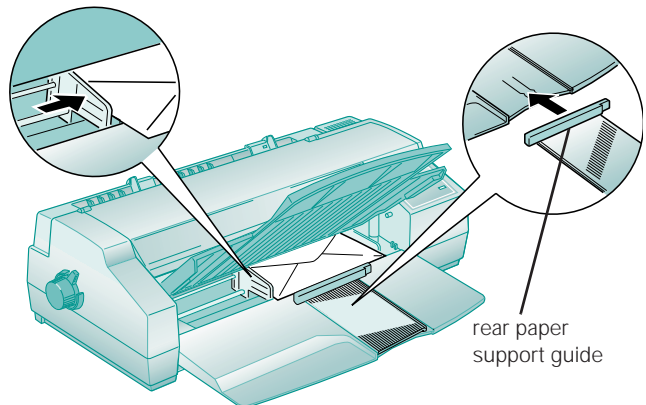

For C5-size envelopes, remove the rear paper support guide and reinstall it backward, sliding it up to the edge of the envelopes.

To load up to 30 ink jet cards, place them **printable side down**, with the short edge leading into the feeder. Remove the rear paper support guide and reinstall it backward, sliding it forward to the edge of the cards.

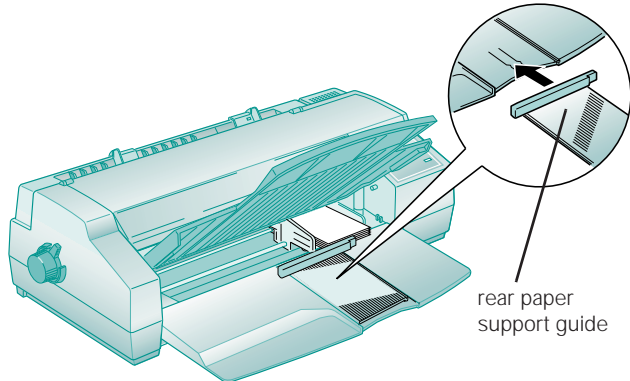

10. Lower the output tray and slide out the output tray extension.
11. Now follow the instructions in Chapters 1 or 2 to select the correct Paper Source, Paper Size, and other settings in your printer software. Then send a print job.
 - ▶ If you run out of paper while printing, reload the sheet feeder and press the Pause button to continue.
 - ▶ If the ink smears on your document, set the thickness lever to the + position and reprint; see page 3-7.
 - ▶ If your margins are not where you like them, adjust them in your application software. However, if the problem seems to be with your paper's loading position, you can change it using the Micro Adjust buttons; see page 3-20 for instructions.



Note:
Make sure that paper isn't loaded in the manual feeder at the top of the printer before sending your print job. If paper is loaded in the manual feeder, the printer will print on it instead of the paper in the built-in sheet feeder.



Note:
To load banner paper, canvas cloth, or other roll paper in the manual feeder, you must also use the optional Banner Paper Kit. See page 3-22 for instructions.

Loading Paper in the Manual Feeder

You can load **one** single sheet of paper in the manual feeder without removing paper from the built-in sheet feeder. Load any type of paper that is between 4.1 inches (105 mm) and 17 inches (432 mm) wide.

1. Turn on the printer, but don't send a print job before you load paper in the manual feeder; always load paper first.
2. Set the paper release lever to the single sheet position (the single sheet icon appears beneath the lever handle).

single sheet icon

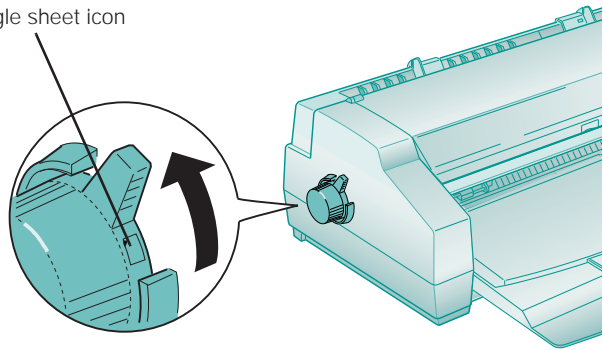

3. Open the printer cover and set the thickness lever to the 0 position when you print on plain paper, ink jet paper, transparencies, transfer paper, or labels.

Set it to the + position when you print on envelopes, ink jet cards, or heavy paper.

0 position

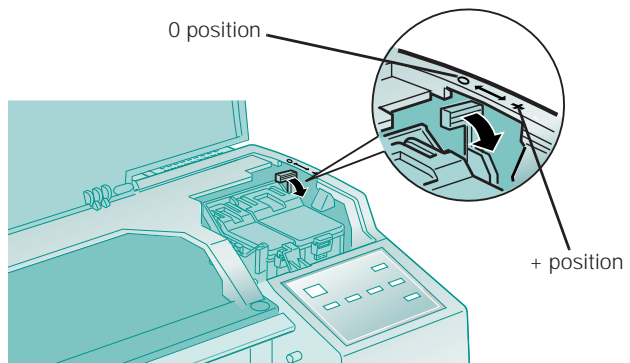

4. If any paper is currently loaded in the paper path from the built-in sheet feeder or the tractor feeder, press the Load/Eject button to eject the paper or park it out of the way.
5. If you'll be printing on paper that is 14.3 inches (364 mm) wide or less, slide the **right** edge guide on the manual feeder so its right edge aligns with the arrow mark on the manual feed guide.

If the paper is more than 14.3 inches (364 mm) wide, slide the **right** edge guide all the way **right**.

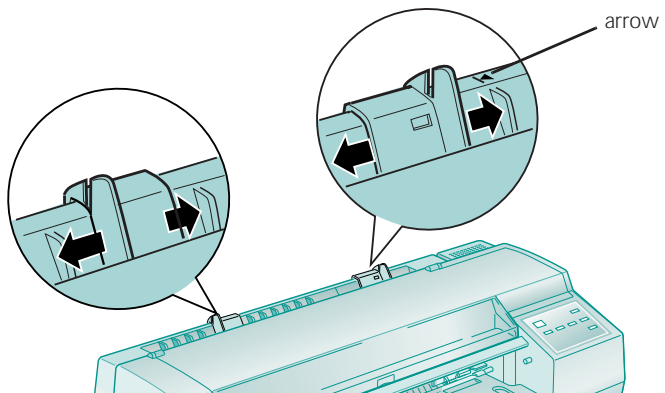

6. Slide the **left** edge guide to the width of your paper. Then load the paper with the printable side **face up** and its right edge against the right edge guide. Gently slide the paper into the manual feeder until the printer pulls it in.

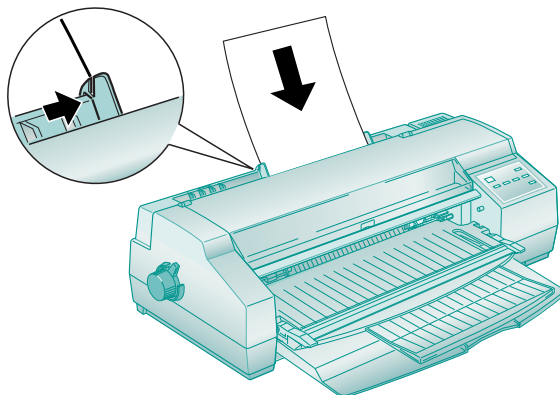

You can load one envelope in the manual feeder **face up** with the flap edge leading into the feeder. Gently slide the envelope into the manual feeder until the printer pulls it in.

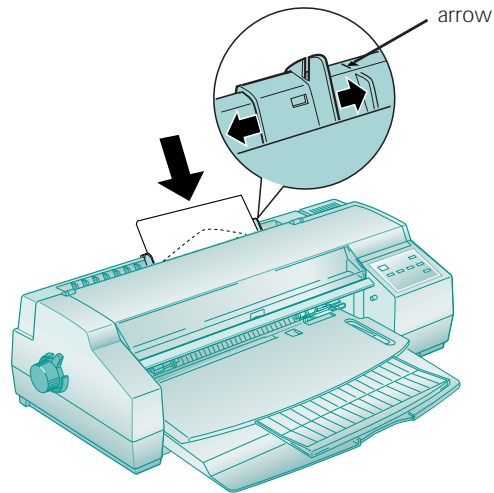

If the paper doesn't load straight, press the Load/Eject button to eject the paper; then load it again.



Note:
Make sure that paper isn't loaded in the manual feeder at the top of the printer before sending a print job for paper in the built-in sheet feeder. If paper is loaded in the manual feeder, the printer will print on it instead of the paper in the built-in sheet feeder.

7. Now follow the instructions in Chapters 1 or 2 to select the correct Paper Source, Paper Size, and other printer software settings. Then send a one-page print job.
8. When your print job is finished, the Pause and Paper Out lights come on. Press the Pause button to turn off the lights.
 - If you want to print another document in the manual feeder, load the paper as described above. To print on paper in the built-in sheet feeder, just send a print job.
 - If the ink smears on your document, set the thickness lever to the + position and reprint; see page 3-7.
 - If your margins are not where you like them, adjust them in your application software. However, if the problem seems to be with your paper's loading position, you can change it using the Micro Adjust buttons; see page 3-20 for instructions.



When you print on continuous paper, it's a good idea to turn on auto tear-off mode so the printed paper can advance to the tear-off position automatically. Follow the instructions on page 5-3.



Caution:
If you load **continuous label** paper, make sure the printer's auto tear-off feature is turned off. If you have this feature turned on, labels could be fed backward and peel off inside the printer. See page 5-3 for instructions on checking or changing the setting using default-setting mode.

Printing on Continuous Paper

You can load continuous paper in the built-in tractor feeder on the back of the printer without removing paper from the built-in sheet feeder. Load any type of continuous paper that is between 4 inches (102 mm) and 16 inches (406 mm) wide, such as greenbar paper, fanfold banner paper, or continuous label paper.

1. Turn on the printer, but don't send a print job before you load paper on the tractor feeder; always load paper first.
2. Set up your printer so there's enough room in the back to feed the paper and enough room in front for the printed pages to stack without obstruction. Position the paper supply within 3 feet (1 meter) of the printer.

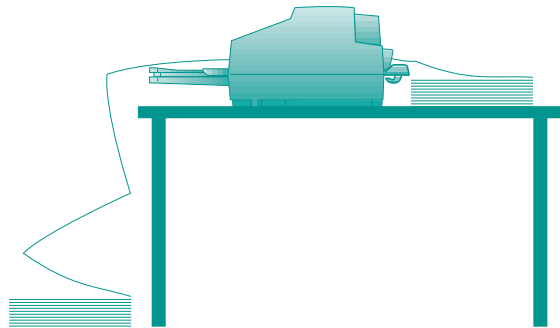

3. Set the paper release lever to the continuous paper position (the continuous paper icon appears above the lever handle).

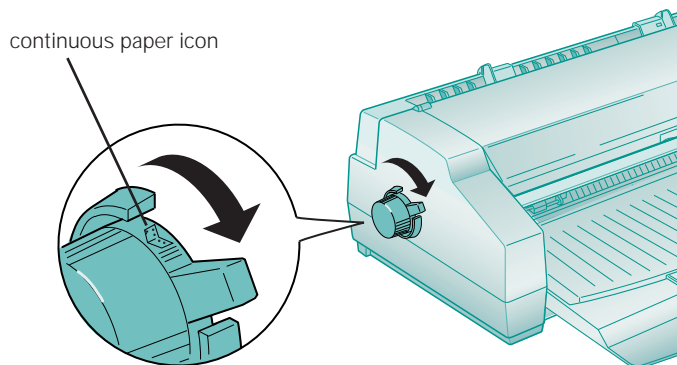

4. Make sure the thickness lever is in the 0 position; see page 3-11 for instructions.
5. Remove the manual feeder from the top of the printer by pulling it straight back. Then set it aside.
6. Install the cable cover by inserting the three posts on the cover into the three holes on the back of the printer. Press the cover down until it locks in place.

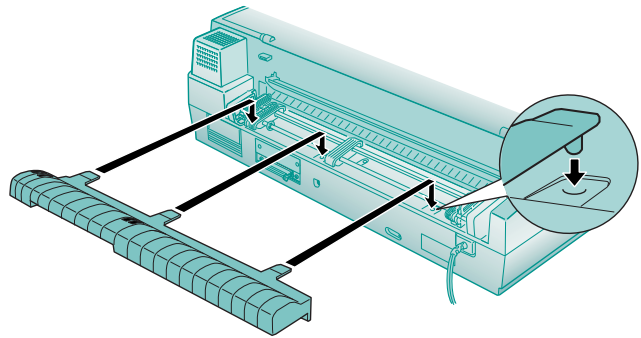

To hold the printer cables away from your paper supply, loop them into the hooks underneath the cable cover.

7. Pull up the sprocket-lock levers to unlock them so you can slide the sprockets into position.

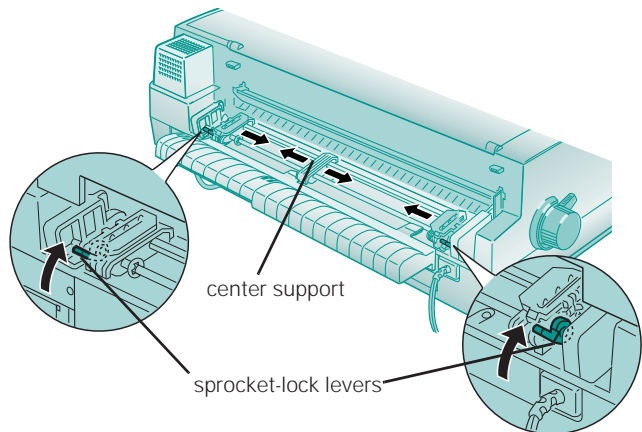

8. Slide the **left** sprocket all the way **right** until it stops. Press down the sprocket-lock lever to lock it in place.

Printing on Special Media



Note:
The maximum printable
width is 13.6 inches
(345 mm) on any size
paper.

- Slide the right sprocket to the approximate width of your paper. Then position the center support midway between the two sprockets, as shown in the previous illustration.
- Flip open both sprocket covers.

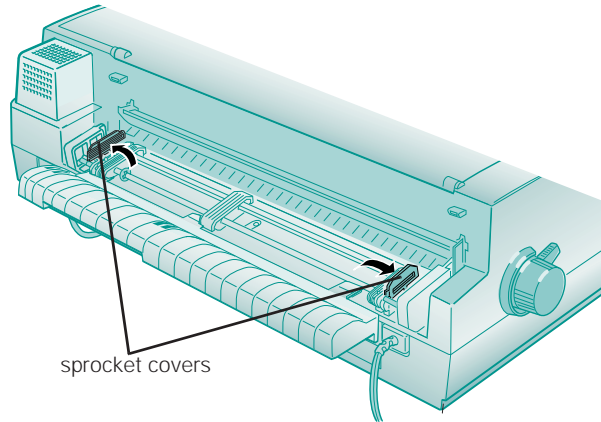

- Arrange the continuous paper stack so the printable side is **face up**. Fit the first four holes over the sprocket pins on both sprockets; then close the sprocket covers.

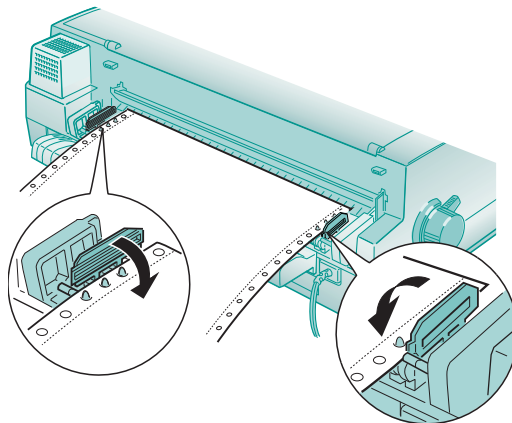

- Slide the **right** sprocket to remove any slack in the paper. Then press down the sprocket-lock lever to lock it in place.

If necessary, align your stack of continuous paper so it will feed straight into the tractor feeder.

13. Reinstall the manual feeder on the top of the printer.

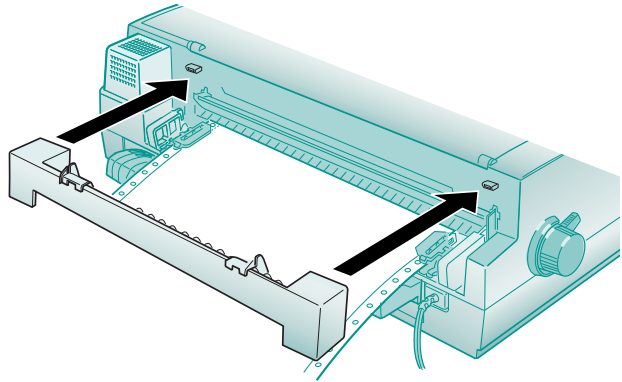

14. Slide out the output tray extension. Then make sure the edge of the rear paper support guide is beneath the extension so the continuous paper doesn't catch on it as it ejects.

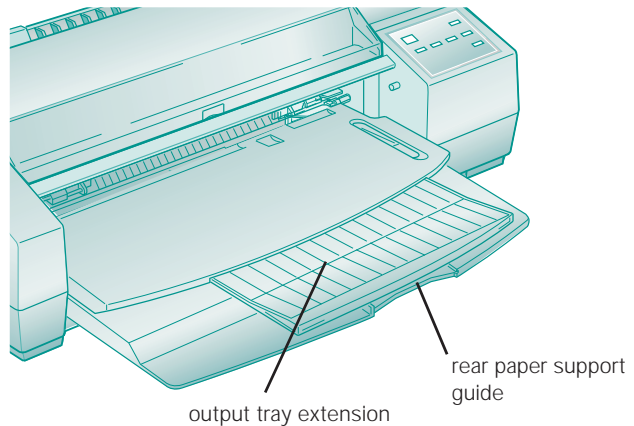

Note:
If you run out of continuous paper while printing, the Paper Out  and Pause lights come on. Load more paper on the tractor feeder and press the Pause button to continue printing.

15. Follow the instructions in Chapters 1 or 2 as necessary to send a print job. Be sure to select Tractor Feeder as the Paper Source option and then choose the correct Paper Size. The continuous paper loads and printing begins when the printer receives the print job.

Follow the steps in the next section to remove continuous paper correctly.

Removing Continuous Paper

When you've finished printing a continuous paper document, you must carefully follow these steps to remove it from the printer, depending on your media type and the setting of the auto tear-off feature.



Note:
See Chapter 5 for information on using default-setting mode to change the auto tear-off setting for your print job.

1. If the printer's auto tear-off feature is turned **on**, your continuous paper is automatically advanced to the tear-off position at the end of a print job. Go to step 2.

If the auto tear-off feature is turned **off** (the default setting), press the LF/FF button as many times as necessary to advance the last printed sheet to the tear-off edge. Go to step 2.

If the auto tear-off feature is turned **off** (the default setting) and you're printing labels, tear off the next sheet of labels at the **back** of the printer. Then press the LF/FF button on the printer's control panel as many times as necessary to eject the remaining pages forward out of the printer. **Do not perform steps 2 and 3.**

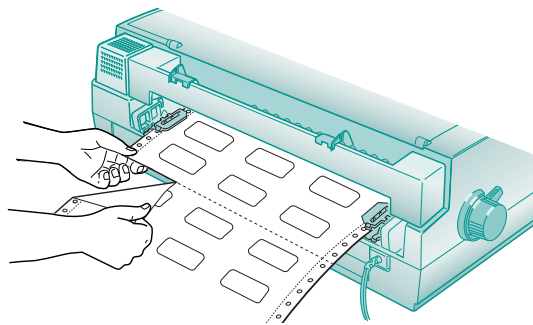

2. Tear off the printed pages at the perforation by pulling it across the tear-off edge.

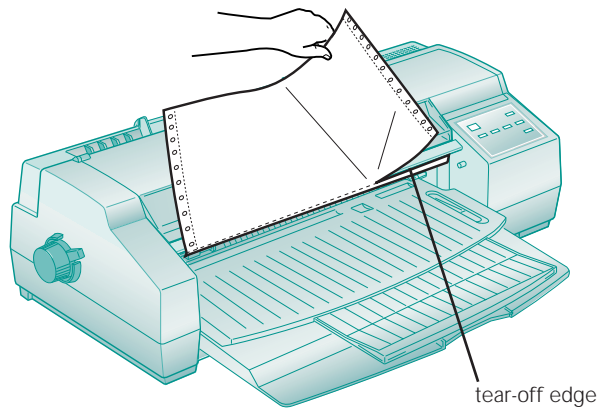

Caution:
Never press Load/Eject when you have continuous label paper loaded in the printer. This would feed labels backward, causing them to peel off inside the printer.

- If the paper's perforation isn't at the printer's tear-off edge, adjust the tear-off position as described on page 3-21. **Do not perform step 3.**
3. Press the Load/Eject button to feed the rest of the continuous paper backward to the paper-park position so it's ready for printing the next time you need it.

If the ink smears on your document, set the thickness lever to the + position and reprint; see page 3-7.

If your margins are not where you want them, adjust them in your application software. However, if you need to adjust your paper's loading position, you can change it using the Micro Adjust buttons. See the next section for instructions.



Caution:
Never use the knob on the left side of the printer to adjust the loading or tear-off positions. This would damage your printer and cause it to lose the top-of-form position.

Using the Micro Adjust Buttons

The Micro Adjust  and Micro Adjust  buttons on your printer's control panel allow you to make quick adjustments to your paper's loading and tear-off positions.

Adjust the paper's loading position if you notice that printing is too high or low on the page and the position cannot be corrected in your software program. You can even set separate loading positions for continuous paper, manually fed paper, or sheet-feeder fed paper.



If you're using continuous paper and the perforation does not align with the printer's tear-off edge when you're done printing, you can use these buttons to adjust the tear-off position.

Adjusting the Loading Position

Follow these steps to adjust the loading position of your paper:

1. If you have continuous and single sheet paper loaded at the same time, the loading position you adjust is determined by the setting of the paper release lever.

For continuous paper, set it to the continuous paper position. For paper in the sheet feeder or the manual feeder, set it to the single sheet position.

2. Press the Load/Eject button to load a sheet of paper or load the first continuous sheet to the top-of-form position.
3. Press the Micro Adjust  button to feed paper **backward** or the Micro Adjust  button to feed paper **forward**. Press either button as many times as necessary to adjust the position. When the adjustment reaches the maximum setting for your printer, it does not move further.
4. Follow the instructions in Chapters 1 or 2 as necessary to send a print job.



Note:
The loading position you select remains in effect until you change it again, even when you turn off the printer.

Adjusting the Tear-off Position



Caution:
Never adjust the tear-off position when you're printing labels. This could feed labels backward, causing them to tear off inside the printer.

First make sure that continuous paper is loaded in the current tear-off position (see page 3-18 for details). Follow these steps to adjust the tear-off position:

1. Press the Micro Adjust **▲** button to feed paper **backward** or the Micro Adjust **▼** button to feed paper **forward**. Press either button as many times as necessary to align the perforation with the tear-off edge. When the adjustment reaches the maximum setting for your printer, it does not move further.
2. Tear off any printed pages.
3. Press the Load/Eject button to feed the rest of the continuous paper backward to the paper-park position so it's ready for printing the next time you need it.

The tear-off position you select remains in effect until you change it again, even when you turn off the printer.

For instructions on setting your printer's auto tear-off mode, see page 5-3.

Switching Between Continuous and Single-sheet Paper

When you have both continuous paper and single sheet paper loaded in the built-in sheet feeder, you can switch between paper types whenever you need to print on them. Follow these steps:

1. If continuous paper remains inside the printer, tear off the printed pages. Then press the Load/Eject button on the printer's control panel to feed the paper backward to the paper-park position.

If single sheet paper is loaded, press the Load/Eject button to eject any sheets still inside the printer.



Note:

If the Pause and Paper Out  lights flash, you may have changed the paper release lever position when paper was still loaded. Set the lever back to its original position and press the Load/Eject button to eject or park the paper. Then set the lever to its new position.

2. To switch to single sheet printing, move the paper release lever to the single sheet position.

To switch to continuous paper printing, move the paper release lever to the continuous paper position.

3. Follow the instructions in Chapters 1 or 2 to change the Paper Source, Paper Size, and other printer software settings. Then send a print job. The printer loads the type of paper you selected when it receives the print job.

Printing a Banner or Other Roll Paper Project

You can use EPSON banner paper or canvas cloth to print strong, attractive banners or other projects up to 44 inches long. EPSON Ink Jet Canvas Cloth has a cloth-like texture—much like artist’s canvas for paintings—that gives a distinct look to your printed images.

First follow the instructions below to load the banner paper or canvas cloth from a roll using the optional Banner Paper Kit. (You can also print a banner on continuous computer paper. See page 3-14 for paper loading instructions.) Then see the appropriate printing instructions for your software—Windows or Macintosh—in the sections that follow.



Note:

To print on roll paper, you need the optional EPSON Banner Paper Kit (C81101*). Contact your EPSON dealer or EPSON Accessories at the phone number on page 3-2.

Loading Roll Paper

1. Before you load roll paper, follow the instructions on page 5-3 to set up the printer for banner printing using default-setting mode. Select these options:
 - Turn banner mode **on** so the printer doesn’t advance too much roll paper out of the printer if you press the LF/FF button.
 - Turn auto tear-off mode **on** so the printer can advance the roll paper to the correct cut-off position.

When you've finished setting these options, turn off the printer to exit default-setting mode. Wait five seconds, then turn on the printer again before performing step 2.

2. Make sure the paper release lever is set to the single sheet position. (See page 3-6 for instructions.)
3. Remove the manual feeder from the back of the printer so you can install the banner paper holders on it.

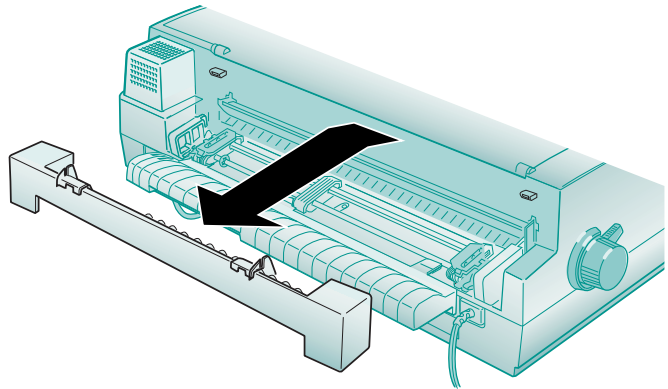

4. Remove the edge guides from the manual feeder by pushing off their bottom edges from inside the manual feeder.

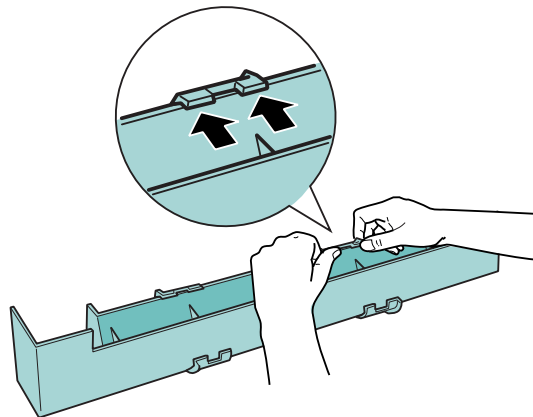

5. Attach the banner paper holders to the front of the manual feeder by positioning the top edges first, then snapping down the bottom edges.

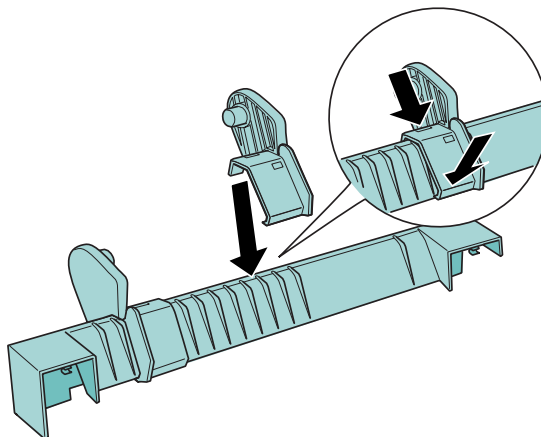

6. Reattach the manual feeder to the back of the printer.

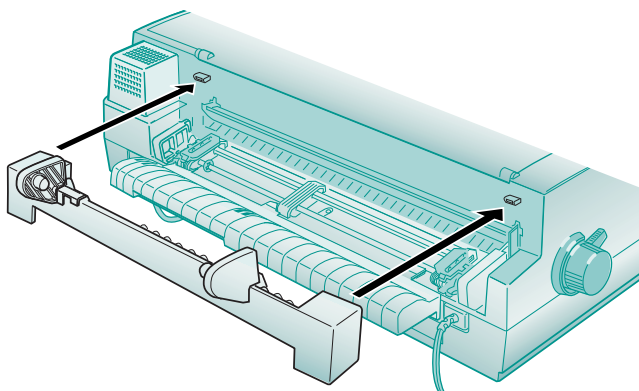

7. Clip the banner paper cutting guide onto the output tray posts.

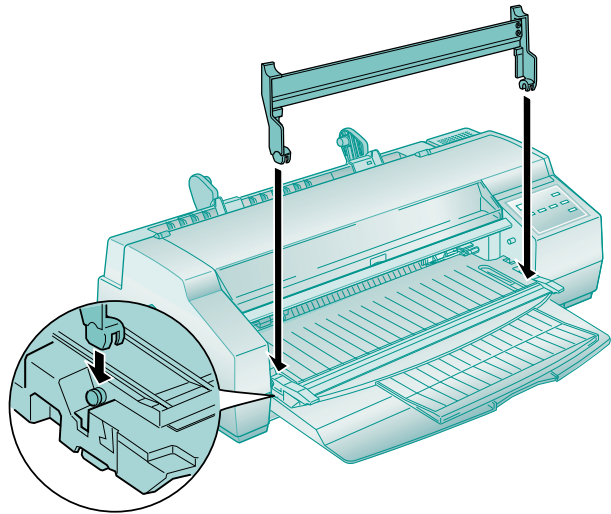

8. Slide the **left** banner paper holder all the way to the **left** and slide the **right** banner paper holder approximately 1/8-inch (3 mm) from the far right edge.
9. Position the roll paper so it feeds into the printer as shown below, with the printable side **face up**. Then place it onto the right banner paper holder and slide the left holder over to support the roll. Align the roll paper's edges with the edge guides on the holders.



Caution:
Adjust the banner paper holders so they fit the roll paper snugly, but not so tightly that the roll can't rotate. If they're too tight, the paper won't feed into the printer.

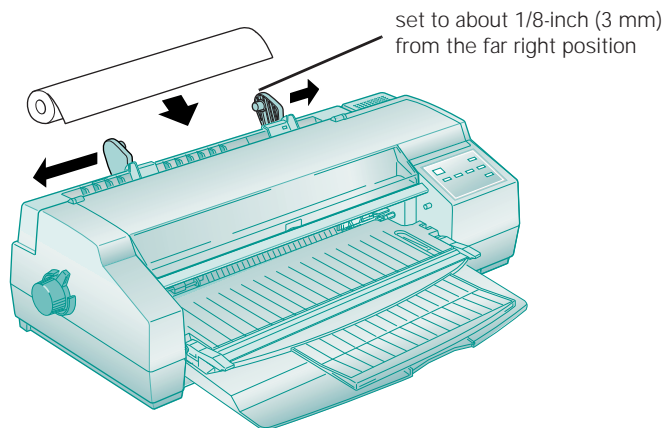

10. Grasp both sides of the roll and slowly unroll the paper into the slot in the manual feeder.

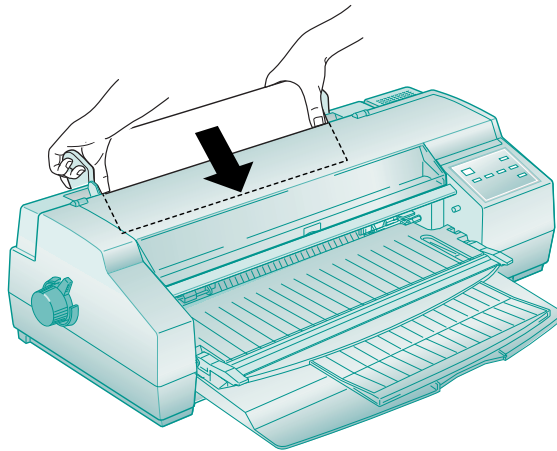

When the roll paper is fully inserted, the printer pulls it in and loads it automatically. (If the paper is crooked, press the Load/Eject button to unload it and try again.)

11. Before you print, raise the cutting guide to an upright position so the roll paper feeds beneath it.

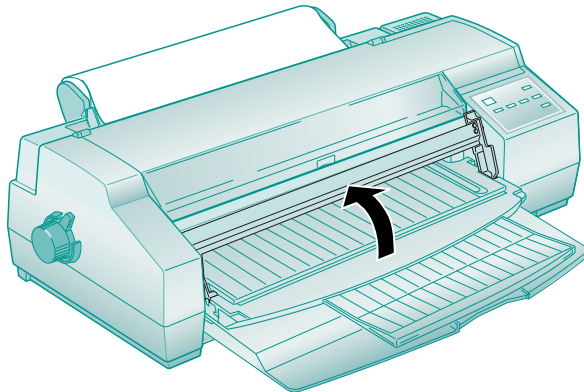

12. Follow the instructions in the next sections to print your banner on either a Windows computer or a Macintosh.

Printing a Banner from Windows

Follow these steps to print a banner or other custom-size project from a Windows application:

1. Create the document in your word processor or other application software.
2. Choose Print or Print Setup from the File menu. You see a printing dialog box for your application.
3. Make sure your printer is selected, and then click the Printer, Setup, Properties, or Options button. (You may have to click a series of these buttons, depending on your software.) You see the Main printer settings dialog box, as shown on page 1-2.
4. Click the Paper tab. You see a dialog box like the following:

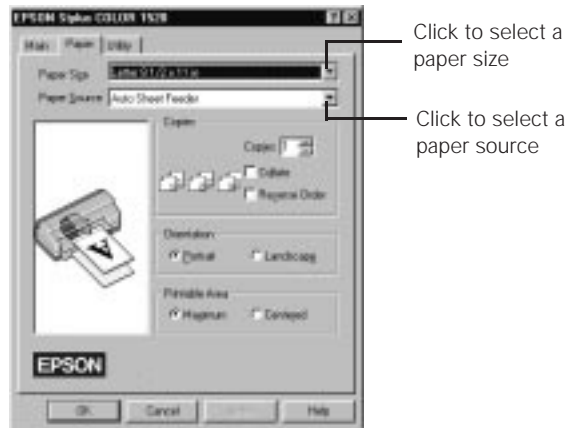

5. If you're printing on roll paper, select Manual Feed Slot (Banner) from the Paper Source list. Go to step 6.

If you're printing a banner on continuous computer paper, select Tractor Feeder for the Paper Source. Go to step 7.



Note:

With Windows NT, the User Defined Paper Size dialog box includes settings for units of measure, naming of the paper size (up to 16 characters), and saving of multiple user defined paper sizes. For instructions on using these settings, click the Help button at the bottom of the Paper dialog box.

Some applications may allow you to print banners longer than 44 inches; see your application program documentation for details.

6. At the end of the Paper Size list, select one of the Long Paper $17 \times n$ in. options, where n is the length of your banner (up to 44 inches). Go to step 8.
7. At the end of the Paper Size list, choose User Defined. The following dialog box appears:

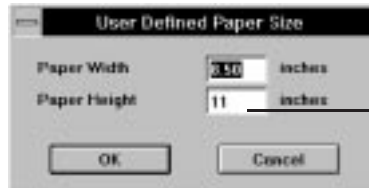

For banner printing, type any size up to 44 inches

Type in your paper's width in the Paper Width field and a length up to 44 inches for the Paper Height. (This works for banners using either landscape or portrait orientation.) Click OK. Go to step 8.

8. Choose Portrait or Landscape, depending on the orientation of the banner or document you created. Set the printable area if necessary.
9. Click the Main tab to return to the Main printer settings dialog box.
10. Choose the Media Type setting that matches your banner paper or canvas cloth as described in the table on page 3-3. (For continuous computer paper, choose Plain Paper.)

Check the rest of the printer software settings as described in Chapters 1 and 2. Then click OK.
11. Click Close, OK, or Print to print your banner.
12. When it's finished printing, follow the steps on page 3-30 to remove your banner from the printer. To remove continuous paper, see page 3-18.

Printing a Banner from a Macintosh

Follow these steps to print a banner or other custom-size project on a Macintosh:

1. Create the document in your word processor or other application software.
2. Choose Page Setup from the File menu. You see a dialog box like the following:

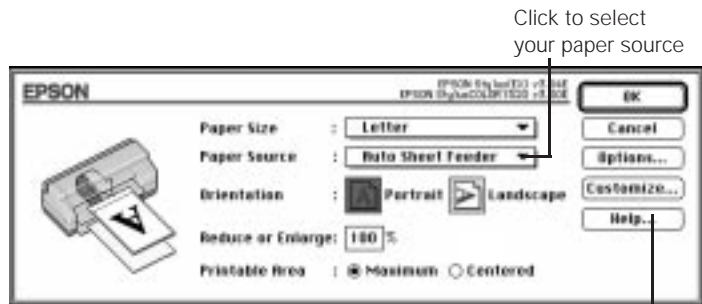

Click to define a custom paper size

3. If you're printing on roll paper, select Manual Feed Slot (Banner) from the Paper Source list.

If you're printing a banner on continuous computer paper, select Tractor Feeder for the Paper Source.

4. Click the Customize button. The following dialog box appears:



You can create up to eight custom paper sizes. Give each one a unique name so you'll be able to reuse them by selecting them from the Page Size list in the Page Setup dialog box.

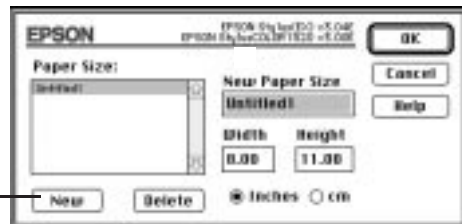

Click to create a new paper size

5. Click the New button.



Note:
Some applications may allow you to print banners longer than 44 inches; see your application program documentation for details.

6. Type a name for your custom-size paper in the New Paper Size box. Then type your paper's width in the Width field and a length of up to 44 inches for the Height. (This works for banners using either landscape or portrait orientation.) Click OK.
7. Choose Portrait or Landscape, depending on the orientation of the banner or document you created. Set the printable area if necessary.
8. Click OK.
9. Choose Print from the File menu or click the print icon in your application. You see the printer settings dialog box (as shown on page 1-9).
10. Choose the Media Type setting that matches your banner paper or canvas cloth as described in the table on page 3-3. (For continuous computer paper, choose Plain Paper.)
11. Check the rest of the printer software settings as described in Chapters 1 and 2. Then click Print to print your banner.
12. When it's finished printing, follow the steps in the next section to remove your banner from the printer. To remove continuous paper, see page 3-18.

Removing a Printed Banner

Follow these steps to remove a printed banner using the cutting guide:

1. Lower the banner paper cutting guide over the top of the paper.
2. If you turned auto tear-off mode **on** (as instructed in step 1 on page 3-22), the printer automatically feeds the paper to the tear-off position when it's finished printing. If you didn't turn on auto tear-off mode, press the LF/FF button to advance the paper to the tear-off position.



Note:
The roll paper cut-off position you set remains in effect until you change it again, even when you turn off the printer.

Press Micro Adjust \downarrow and Micro Adjust \uparrow buttons as necessary to move the end of the banner to the cut-off position on the banner paper cutting guide.

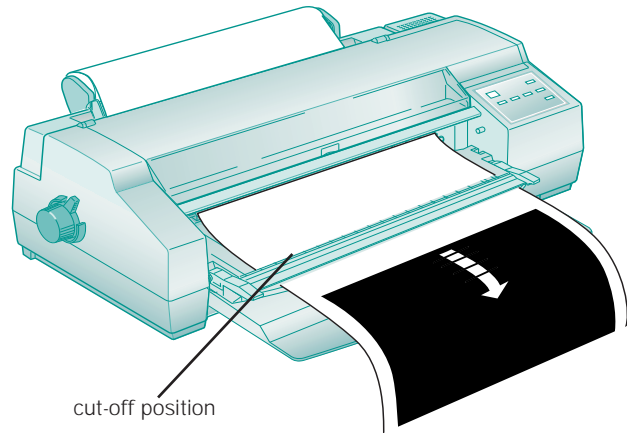

3. Hold down the cutting guide. Then, using a sharp knife, cut straight across the paper, pressing the knife against the inside edge of the cutting guide and on top of the metal strip on the output tray.



Warning:
Keep your hands away from the knife so you don't cut yourself.

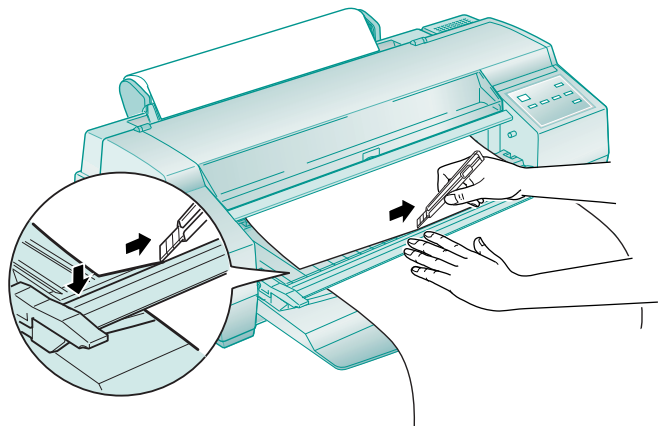

4. Remove the printed paper and raise the cutting guide to its upright position.

5. If you want to print another roll paper project, the printer will feed the roll paper back to the loading position when it receives a new print job. Go to step 10.

If you won't be using the roll paper again right away, continue with step 6.

6. Press the Load/Eject button to eject the paper backward.
7. Using your hands, roll back the paper all the way out of the manual feed slot and onto the roll. When it's completely out, the Pause and Paper Out  lights turn on.
8. Press the Pause button to turn off the lights.
9. If you'll be using the roll paper soon after printing on another type of paper, lower the banner paper cutting guide and push it onto the edge of the output tray until it clicks. This keeps it out of the way of the ejected paper.

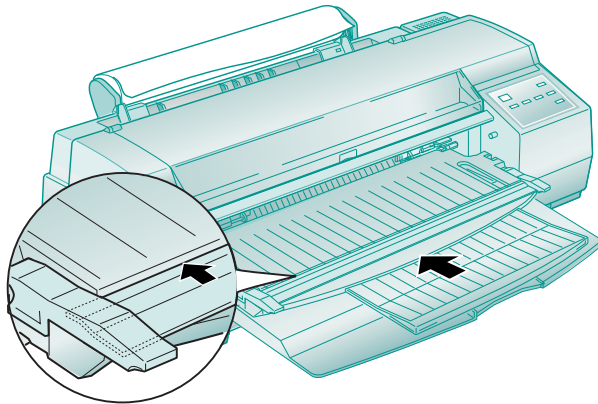

If you won't be using your roll paper for awhile, store it in its original packaging. See Appendix C for optimum storage conditions.

You can use the banner paper holders as your edge guides on the manual feeder, but if you want to remove and reinstall the manual feeder's original edge guides, follow steps 2 through 4 on page 3-23. Then reattach the manual feeder to the printer.

10. Before printing on another type of paper, be sure to change the Paper Source, Paper Size, and Media Type settings in your printer software as described in Chapters 1 and 2.

Also be sure to turn off banner mode using the default-setting mode instructions on page 5-3.

If you'll be printing on continuous paper, also be sure to reset the paper release lever, as described on page 3-14.

Printing a Backlit Display

You can use EPSON Ink Jet Back Light Film to print crisp, translucent images for backlit display. Your printer software automatically makes a mirror image of your design so it appears correctly when viewed from the reverse side. Follow the steps in this section to load a sheet of back light film and select the correct printer settings for a backlit display.

Loading Back Light Film

Before loading the back light film, make sure the sheet is flat. If the film curls, place it between two sheets of paper and put a heavy object on top to flatten it.

Load **one** sheet of back light film as follows:

- ▶ Load it in the built-in sheet feeder with the printable, non-glossy, white surface **face down** following the instructions on page 3-6.
- ▶ Load it in the manual feeder with the printable, non-glossy, white surface **face up** following the instructions on page 3-11.

Printing a Backlit Display from Windows

1. Create the document in your word processor or other application software.
2. Choose Print or Print Setup from the File menu. You see a printing dialog box for your application.
3. Make sure your printer is selected, and then click the Printer, Setup, Properties, or Options button. (You may have to click a series of these buttons, depending on your software.) You see the Main printer settings dialog box, as shown on page 1-2.
4. Select Ink Jet Back Light Film as the Media Type setting. This chooses the best printer driver settings for printing on back light film and automatically turns on the Flip Horizontal feature so your image will appear correctly when viewed from the reverse side.
5. Check the rest of the printer software settings available on the Main menu as described in Chapters 1 and 2.
6. Click the Paper tab.
7. Choose the Paper Source you're using, either Auto Sheet Feeder (for the built-in sheet feeder) or Manual Feed Slot (for the manual feeder).
8. Then select the size of your back light film as the Paper Size setting.
9. Click OK to save your settings and exit the printer software.
10. Click Close, OK, or Print to print your backlit display. (You may need to click a series of these buttons, depending on your software.)



Note:

If you change any other printer software settings, make sure the Flip Horizontal setting is still selected before you print.

Printing a Backlit Display on a Macintosh

1. Create the document in your word processor or other application software.
2. Choose Page Setup from the File menu.
3. Choose the Paper Source you're using, either Auto Sheet Feeder (for the built-in sheet feeder) or Manual Feed Slot (for the manual feeder).
4. Then select the size of your back light film in the Paper Size option. Click OK.
5. Choose Print from the File menu or click the print icon in your application. You see the printing dialog box (as shown on page 1-9).
6. Select Ink Jet Back Light Film as the Media Type setting. This chooses the best printer driver settings for printing on back light film and automatically turns on the Flip Horizontal feature so your image will appear correctly when viewed from the reverse side.
7. Check the rest of the printer software settings as described in Chapters 1 and 2. Then click Print to print your backlit display.



Note:

If you change any other printer software settings, make sure the Flip Horizontal setting is still selected before you print.

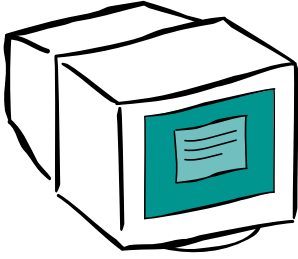

4

Managing Print Jobs and Network Printing

Your printer software includes several utilities for managing print jobs. You can use them to monitor your printer's status, set up large jobs to print later, and handle network printing. If you're using your printer on a network, you need to follow the special setup procedures in this chapter.

This chapter provides instructions for the following:

- Managing print jobs with Windows 95 or 3.1
- Managing print jobs with Windows NT
- Managing print jobs on a Macintosh
- Network printing on a PC
- Network printing on a Macintosh

Managing Print Jobs with Windows 95 or 3.1

Your Windows printer software includes two management utilities: the Spool Manager and Status Monitor.

- The Spool Manager starts automatically when you send a job to the printer. It allows you to print in the background while you continue to work on your computer and to hold jobs to print at a later time. If you're using your printer on a network, it also handles multiple print jobs that come in at the same time.



Note:
The Status Monitor doesn't appear if you're printing over a network.

In Windows 3.1, you may not see the Spool Manager icon if the Program Manager or current window is maximized. Make the window smaller to see the Spool Manager icon.

- The Status Monitor, which is available only if you're using Windows 95, also starts automatically when you send a job to the printer. It displays on your screen to alert you about printer and ink status.

Using the Spool Manager

The Spool Manager works like the Windows Print Manager. When you send a job to your printer, your printer software creates a temporary print job file, stores it in the C:\TEMP or C:\WINDOWS\TEMP folder or directory, and assigns it to a print queue. The software then sends the file to your printer at the right time.

- To open the Spool Manager while you're printing, click the Spool Manager icon that appears on the Taskbar (Windows 95) or at the bottom of your desktop (Windows 3.1).
- To open it at any time, double-click the Spool Manager4 icon in the EPSON program group or folder.

You see the Spool Manager window:

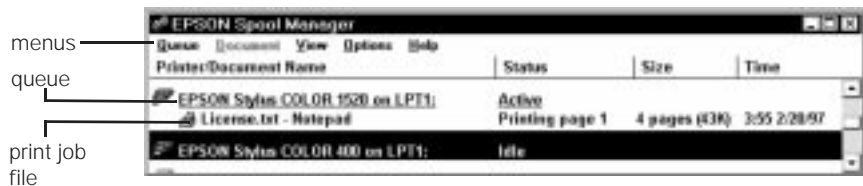

The Spool Manager window displays the status of your print queues and print jobs and lets you control them. Here are some of the things you can do:

- Hold or release a queue
- Send print jobs to your printer over a network
- Hold, re-queue, or delete a print job



For information about any of these procedures, use the Spool Manager Help utility.

- ▶ Prevent the Despooler window from appearing on your screen whenever you print (see page 1-7 for information on the Despooler window)
- ▶ Change your default spool directory

Deleting a Stalled Print Job

If you have trouble printing, it may be because of a stalled print job. Follow these steps to delete it so you can continue printing:

1. Open the Spool Manager as described on page 4-2.
2. Click on any print jobs marked Held, then open the Document menu and click Delete.
3. Click Yes.
4. Exit Spool Manager and try printing again.

Changing the Default Spool Directory

If you get an error message when you try to print, or printing is very slow, you can try changing your default spool directory. Follow these steps:

1. Make a directory on your hard disk where you want Spool Manager to store print job files, for example, C:\SPLTEMP.
2. Open the Spool Manager as described on page 4-2.
3. Choose Default Spool Directory from the Options menu.
4. In the dialog box, change the spool directory to the one you created in step 1. Then click OK.
5. Make sure EPSON Stylus COLOR 1520 is selected, and then choose Setup from the Queue menu. The Queue Setup dialog box appears.

6. Make sure the spool directory is the same as in step 1. Also make sure Use Print Manager for this port is checked. (If you're using Windows 95 and don't see the Status Monitor when you print, leave it unchecked.) Click OK.
7. Close Spool Manager.

Using the Status Monitor

The Status Monitor, available only if you're using Windows 95, displays automatically in the Despooler window when you send a print job to the printer. However, you can use it at any time to see how much ink you have left. Follow these steps:

1. Access the Main printer settings dialog box as described on page 1-2 (Windows) or page 1-9 (Macintosh).
2. Click the Utility tab. You see the Utility menu:

For information about these three utilities, see Chapter 6

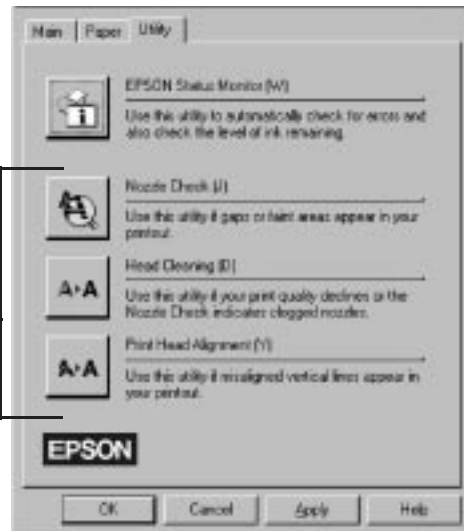

3. Click the EPSON Status Monitor icon.

You see the Despooler window with the Status Monitor at the bottom:

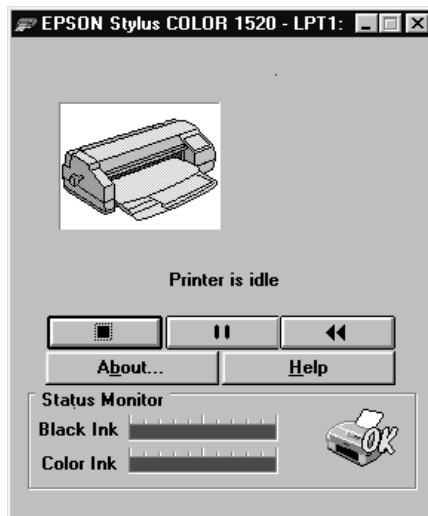

4. Check the amount of ink you have left. (For more information about the Despooler window, see page 1-7.)

Managing Print Jobs with Windows NT

Windows NT 4.0 servers and workstations include a messenger service to alert you to printer errors or let you know when a print job is finished. If you have appropriate network access privileges or you're controlling printing from the server, you can also cancel, pause, or restart print jobs and set the sharing, security, scheduling, and port options. See your Windows NT documentation for details.

You can check the status of your print job in Windows NT 3.51 using the Print Manager. Options in the Print Manager window let you pause, resume, or delete print jobs and handle the print queues on your system, depending on your network access privileges. See your Windows NT 3.51 documentation for instructions.

Managing Print Jobs on a Macintosh

Your Macintosh printer software includes two utilities for managing your print jobs: EPSON Monitor2 and Status Monitor.

- ▶ If you're using background printing, Monitor2 starts automatically when you send a job to the printer. It handles printing while you continue to work on your Macintosh and lets you track documents that are waiting to be printed.
- ▶ The Status Monitor alerts you to any problems that occur during printing. You can also use it any time to see how much ink you have left.

Using EPSON Monitor2

The EPSON Monitor2 utility lets you continue to work on your Macintosh while your document is printing. To use this utility, however, you need to turn on background printing and increase the memory allocation for Monitor2.

Follow these steps:

1. If you didn't turn on background printing when you selected your printer, open the Chooser from the Apple menu. Select either the EPSON Stylus(EX) or EPSON Stylus(AT) icon. Under Background Printing, click On and close the Chooser.
2. To increase the memory allocated to Monitor2, select EPSON Monitor2 in the Extensions folder in your System folder. Then choose Get Info from the File menu and set the Memory Requirements to 2000K or 3000K, depending on your system's available RAM.
3. To use Monitor2 while you're printing, select the EPSON Monitor2 icon in the Application menu at the right end of the menu bar.



Note:
Background printing is slower and may also slow down your system.

You see a dialog box like the following:

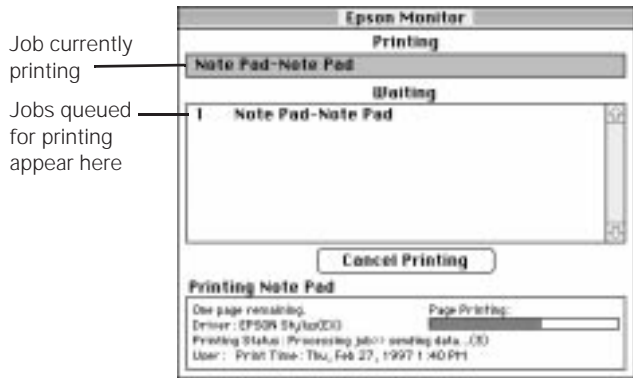

You can select a job and cancel it or just use this window to track the print job's progress.

Using the Macintosh Status Monitor

You can use the Status Monitor to check the level of ink in your printer and to control the way your software warns you about printer problems. Follow these steps:

1. Choose Print from the File menu or click the print icon in your application. You see the printer settings dialog box.
2. Click the Utility button. You see the Utility menu:

For information about these utilities, see Chapter 6



3. Click the Status Monitor icon. The software checks the amount of ink remaining and displays the Status Monitor:

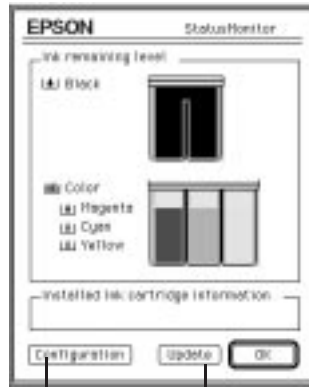

Click to control messages and warnings

Click to recheck ink level

4. If you want to change printer messages and warnings, click the Configuration button. You see the following dialog box:

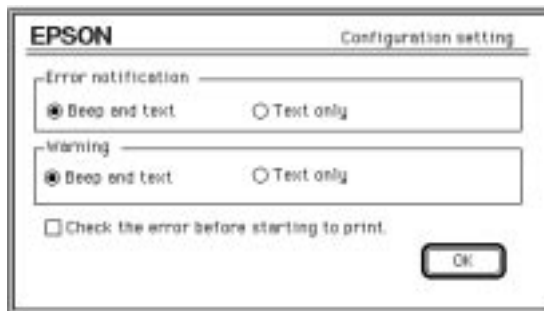

5. Choose the options you want and click OK.



Note:
If you need to install a network interface board in your printer, see Appendix A for instructions.

Network Printing on a PC

You can use your printer on a network under Windows NT, Windows 95, or another network operating system. First you need to set up your printer using either the network's printer setup functions or your printer software's built-in network support.

If you're setting up your printer for Windows NT, see the instructions below. For other network operating systems, see your network documentation for instructions or use the printer software's network support, as described on page 4-11.

Connecting to the Printer on Windows NT 4.0 Systems

If you installed an optional network interface card in your printer and installed the printer software as described in the *Quick Setup* booklet, follow the steps below to connect the remote printer to each system on the network using the TCP/IP (or LPR) protocol.



Note:
If you connected the printer directly to a Windows NT server or you're using a different network protocol, see your Windows NT documentation for instructions on configuring your printer for the network. If you're using an optional interface card, also see the documentation that came with the card.

1. Follow the instructions to configure the interface card in the manual that came with the card.
2. To connect the printer to a TCP/IP (or LPR) port, open the Control Panel and select Printers.
3. Right-click the EPSON Stylus COLOR 1520 icon, then select Properties.
4. Select the Ports tab and click the Add Port button.
5. Select LPR Port in the Port list. Then click New Port.
6. Type the IP address of the card in the first box and type a short name for the printer in the second box. Then click OK.
7. Click Close.

8. You see the address and name of the printer in the Port list. Click OK to exit printer properties.

Now you can print to the remote printer. Repeat these steps for each system on the network that needs to access the printer.

Connecting to the Printer on Windows NT 3.51 Systems



Note:

If you connected the printer directly to a Windows NT server or you're using a different network protocol, see your Windows NT documentation for instructions on configuring your printer for the network. If you're using an optional interface card, also see the documentation that came with the card.

If you've connected the printer to a server, be sure to install the Windows NT 3.51 software on all workstations that will share the printer over the network.

If you installed an optional network interface card in your printer and installed the printer software as described in the *Quick Setup* booklet, follow the steps below to connect the remote printer to each system on the network using the TCP/IP (or LPR) protocol.

1. Follow the instructions to install the LPR software and configure the interface card in the manual that came with the card.
2. To configure the printer for TCP/IP (or LPR) printing, double-click the Print Manager icon in the Main program group.
3. Select the EPSON Stylus COLOR 1520 window.
4. Choose Properties in the Printer menu.
5. Select Other in the Print to list.
6. Select LPR Port in the Available Print Monitors list and click OK.
7. Type the IP address of the card in the first box and type a short name for the printer in the second box. Then click OK.
8. Click OK again, then exit Print Manager.

Now you can print to the remote printer. Repeat these steps for each system on the network that needs to access the printer.

Using the Printer Software's Built-in Network Support

To use your printer software's built-in network support, you first need to install the printer software on all the network computers that will use the printer. See the *Quick Setup* booklet for instructions. Once the printer software is installed, you can set up Spool Manager to send print job files from each computer to a shared directory on the computer connected to the printer.

Follow the steps in the next sections to set up a print job directory on the system connected to the printer (the host system) and each remote system (client) on the network. For Windows 95, you also need to specify the port and network path to the printer, as described on page 4-12.

Setting Up the Host System

Follow these steps to set up the computer connected to the printer:

1. Create an icon for the EPSON Spool Manager (EPSPLMGR.EXE in the \WINDOWS\SYSTEM folder or directory).
2. Place this icon in the Startup folder.
3. Double-click the EPSON Spool Manager icon to open the Spool Manager window.
4. Double-click the queue you want to use for network printing. The Queue Setup dialog box appears.
5. Click the Remote Despool tab and then click the Printing from remote queues option.
6. Click the Browse button and select the remote server directory that will receive print job files.
7. Click OK and minimize the Spool Manager window.

Setting Up Remote Systems

Follow these steps to set up the client computers on the network:

1. Open the Spool Manager window as described on page 4-2.
2. In the Spool Manager window, double-click the queue you want to use for network printing. The Queue Setup dialog box appears.
3. Click the Spool to remote printer button.
4. Click the Browse button and select the directory you're using for print job files on the host system.
5. Click OK and minimize the Spool Manager window.

Setting Up Your Network Path in Windows 95

If you want to use your printer on a network running Windows 95, you need to set up the port and network path on the computer connected to the printer. Follow these steps:

1. Double-click My Computer.
2. Double-click the Printers folder.
3. Right-click the EPSON Stylus COLOR 1520 icon and choose Properties.
4. Click the Details tab.

The following dialog box appears:



Note:
To print from DOS applications as well as Windows applications, click the Capture Printer Port button instead of Add Port. Select the printer port in the Device list, then specify its network path. Select Reconnect at logon, then click OK.

5. Click the Add Port button, then specify the network path to the printer and click OK.
6. Open the Spool Manager window as described on page 4-2.
7. In the Spool Manager window, double-click your printer's queue. The Queue Setup dialog box appears.
8. Make sure the Use Print Manager for this port option is checked. Then click OK.

Network Printing on a Macintosh

If you want to use your printer on an AppleTalk™ network, you need to install an optional interface board: either the LocalTalk® board or the Ethernet™ board. See Appendix A for more information about optional interfaces.

Then you can use the EPSON Namer utility and set up your printer in the Chooser. The EPSON Namer was installed on your hard drive along with the other printer software.

Assigning a Name to the Printer

Follow these steps to use the EPSON Namer utility:

1. Double-click the EPSON Namer icon on your hard drive.
2. Click the EPSON Stylus(AT) icon in the Device Types window.
3. Select the AppleTalk zone where your printer is located.
4. Under New Name, type a name from your printer to distinguish it from other printers on the network.
5. Click Rename and then click Done.

Setting Up the Printer for AppleTalk

Make sure your printer is turned on and then follow these steps to set up your printer on an AppleTalk network:

1. Open the Chooser from the Apple menu. You see a dialog box like the following:

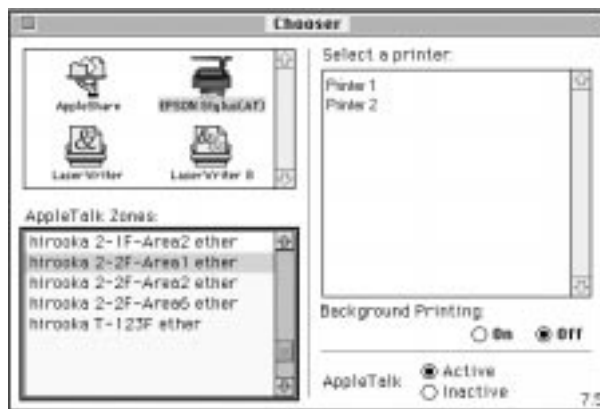

2. Click the EPSON Stylus(AT) icon.
3. Select the AppleTalk zone you want to use. A list of all printers connected to the selected zone appears on the right.

4. Click the name you assigned to your EPSON Stylus COLOR 1520 in step 4 of the previous section. You see a prompt asking you to confirm your choice.
5. Click OK.

If your printer name doesn't appear, make sure the printer is turned on and correctly connected, then click RETRY.
6. To ensure compatibility, leave Background Printing turned off.
7. Close the Chooser.

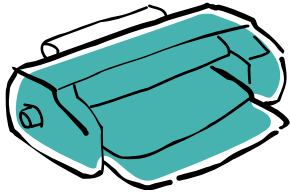

5

Using Your Printer with DOS

If you print with DOS application programs, you can use your printer with them by following the instructions in this chapter. It covers these operations:

- ▶ Selecting printer software for DOS
- ▶ Changing printer settings with default-setting mode
- ▶ Performing printer maintenance procedures, such as aligning the print heads
- ▶ Selecting character tables
- ▶ Using printer commands



Note:

To use your printer with AutoCAD® 386 (DOS Extender) releases 10 and higher that support ADI plotter drivers, see the README file on the ADI plotter driver diskette or printer software CD-ROM.

Selecting Printer Software for DOS

You select software for your printer (a printer driver) in each DOS program you use. Most DOS programs include a driver for EPSON ESC/P 2™ printers. You need to select the correct printer driver to take advantage of your printer's advanced built-in scalable fonts and graphics handling.

Most DOS programs require you to select from a list of available printer drivers. If EPSON Stylus COLOR 1520 is not included in the list, you can contact your software manufacturer to obtain an updated driver.

If an updated driver is not available, pick the first printer available in the lists on the next page.



Note:
The drivers for the printers listed do not provide all EPSON Stylus COLOR 1520 features, such as 1440-dpi printing, 720-dpi printing, and MicroWeave.

When printing black and color, select:

EPSON Stylus 1500
EPSON Stylus Pro
EPSON Stylus Pro XL
EPSON Stylus COLOR 500
EPSON Stylus COLOR II
LQ-2550
LQ-1070

When printing black only, select:

LQ-870
LQ-1170
LQ-500
LQ-570
LQ-570+
LQ-1070
LQ-1070+
SQ-870
SQ-1070
LQ-850

Once you've selected a printer driver for each DOS program you use, you can begin printing. Be sure to check the paper source and other printer driver settings before you print.

If you want to adjust any of the printer's internal settings, you can use default-setting mode as described in the next section.

To perform routine printer maintenance procedures, see page 5-7 for instructions.

Changing Printer Settings with Default-Setting Mode

Your printer includes internal default settings that are active whenever you turn on the printer. These settings control functions such as the print direction and paper loading positions.

Because they are preset to the most likely settings you'll want to use, you probably won't need to change them. However, you may want to change settings such as these for special projects:

- Turn on auto tear-off mode when you print on continuous paper or roll paper (but **not** when printing continuous labels)
- Turn on banner mode when you print on roll paper
- Select a slashed zero (Ø) instead of a regular zero (0) when you print documents where the zero can easily be confused with a capital "O"

You can check or change the default settings using the printer's control panel. Follow the steps in the next section.



Note:

The printer's control panel buttons perform different functions while the printer is in default-setting mode. Be sure to carefully follow the instructions your printer prints and don't try to perform standard control panel functions until you've exited default-setting mode.

Entering Default-Setting Mode

To enter default-setting mode and print an instruction sheet in your language, follow these steps:

1. Load four or more sheets of paper, at least 8.3 inches (210 mm) wide, into the built-in sheet feeder, making sure the right edge guide is positioned correctly for your paper's width and the paper release lever is set to the single sheet position. See page 3-6 for loading instructions.
2. Turn off the printer.

3. Hold down the Micro Adjust \blacktriangledown button and press the \odot Operate button to turn on the printer and enter default-setting mode. Release the Micro Adjust \blacktriangledown button when the Operate light comes on.

The printer loads a sheet of paper and prints an instruction sheet telling you how to select a language (the default setting is English). The printer can then print default-setting instructions in the language you choose.

4. Press the Alt button until the Ink Out \blacklozenge and Ink Out \blacklozenge lights on your control panel indicate the language you want to use.

| | |
|------------|--|
| English | Both lights off |
| French | Ink Out \blacklozenge on and Ink Out \blacklozenge off |
| Spanish | Both lights on |
| Portuguese | Ink Out \blacklozenge flashing and Ink Out \blacklozenge on |
| German | Ink Out \blacklozenge flashing and Ink Out \blacklozenge off |
| Italian | Ink Out \blacklozenge off and Ink Out \blacklozenge on |

5. Press the Pause button. The printer prints instructions on changing the default settings.
6. Follow the instructions on the sheets to change the necessary settings, as listed in the next section. Your changes remain in effect until you change them again. (To exit without changing any settings, press the Pause button.)
7. When you're finished changing settings, press Load/Eject if you need to eject any loaded paper. Then turn off the printer to exit default-setting mode.
8. Wait five seconds, then turn on your printer to resume printing normally.

List of Default-Setting Options

The table below lists all the options available for each default setting. The factory defaults are listed in **bold** type in the table below. The printer's current settings are marked with a ← on your printed instruction sheet.

| Setting | Options | Description |
|--------------------------------|---|--|
| Print direction | Auto , Bi-D, Uni-D | Auto switches between bidirectional printing for text data (the print head prints in both directions) and unidirectional printing for graphics data. For the fastest printing of text only, select Bi-D; but if vertical lines become misaligned, you'll need to turn it off or align the print heads (see page 5-7 for instructions). For the most accurate alignment when printing graphics, select Uni-D. |
| Font | Courier , Roman, Sans Serif, Script Prestige, Roman T, Sans Serif H, Draft | If your software doesn't let you select fonts, you can select one of these bitmap or scalable fonts. See Appendix C for a list of the point size and characters per inch available with each font. |
| Pitch | 10 , 12, 15, 17.1, or 20 cpi, or Proportional | If your software doesn't let you select point size or characters per inch for your fonts, you can select one of these. See Appendix C for a list of the point size and characters per inch available with each font. |
| I/F (interface) mode | Auto , Parallel, Serial, Option | When your printer is connected to multiple interfaces, Auto sets the printer to receive data from any interface sending a print job. Select Parallel, Serial, or Option only if you want your printer to ignore print jobs sent from other interface types. |
| Auto I/F (interface) wait time | 10 or 30 seconds | If you choose Auto for the I/F mode setting, selects the time the printer waits for a print job from one interface before accepting a print job from another interface. |

| Setting | Options | Description |
|--|--|--|
| Software (emulation mode) | ESC/P 2 , IBM XL24E | Specifies the control mode you want the printer to use. For the best font and graphics control, always use ESC/P 2 mode. If you need to emulate an IBM® Proprinter,™ select IBM XL24E mode. For a list of the commands for these modes, see page 5-17. |
| Auto CR (IBM XL24E mode only) | Off , On | In IBM XL24E mode, lets you select whether the printer performs a carriage-return line-feed operation when it reaches the right margin (On) or only when it receives a carriage-return code in the print job (Off). |
| AGM (IBM XL24E mode only) | Off , On | In IBM XL24E mode, turns high resolution, 24-pin graphics command mode on or off. |
| Character table | — | See the samples beginning on page 5-8. The default character table is PC437 . |
| International character set for Italic table | — | See the samples beginning on page 5-8. The default character set is Italic U.S.A. |
| Auto line feed | Off , On | Sets the printer to perform a line-feed operation every time it receives a carriage-return command (On), or not to perform one (Off). |
| Network I/F (interface) mode | Off , On | Sets whether the printer is (On) or is not (Off) shared by more than one computer. |
| 0 slash | 0 , Ø | Selects either a slashed zero (Ø) or a regular zero (0) to be printed when a zero command is received. |
| Page length | 11 , 12 , 8.5 , or 70/6 inches | When printing on continuous paper, select the length of the individual sheets. 70/6 is the length of A4-size paper. |
| Skip over perforation | Off , On | If your software doesn't let you set top and bottom margins, turn this setting On to add a one-inch margin over the perforation to separate text on continuous pages. |

| Setting | Options | Description |
|--|----------------------|--|
| Auto tear off | Off , On | When printing on continuous paper or roll paper, turn this setting On to advance the perforation or end of the roll paper document to the printer's tear-off edge. It also backs the paper up to the top-of-form position when it receives the next print job. Turn this setting Off when printing on continuous labels so they don't peel off inside the printer. |
| Banner mode | Off , On | When you turn this mode On, roll paper is treated like continuous paper, even with the paper release lever in the single sheet position. This prevents the printer from advancing too much roll paper forward when you press the LF/FF button. |
| Parallel I/F (interface) transfer rate | Fast , Normal | Sets the transfer rate for printing across the parallel port. Always select Fast unless you receive transfer rate errors. |

Maintaining the Printer



If vertical lines are misaligned, first make sure you did not set the Print direction setting to Bi-D (bidirectional) in default-setting mode. This may be causing the problem instead of truly misaligned print heads. See page 5-3 for instructions on checking your default settings.

When you're printing from DOS applications, you can perform most printer maintenance operations as they're described in Chapter 6, such as replacing the ink cartridges and cleaning or aligning the print heads from the control panel.

However, you can use a DOS utility as described in this section if you need to align the print heads to correct misaligned vertical lines.

Aligning the Print Heads with a DOS Utility

Before you can align the print heads, you need to install the DOS alignment utility. Follow these steps:

1. Make sure your computer and printer are turned on.

2. Load several sheets of paper at least 8.3 inches (210 mm) wide in the built-in sheet feeder, making sure the right edge guide is positioned correctly for your paper's width. Also make sure the paper release lever is set to the single sheet position. (See page 3-6 for instructions.)
3. Insert the EPSON printer software CD-ROM or diskette into a drive.
4. At the DOS prompt, type `d:\SETUP` (where *d* is the drive letter of your drive) and press Enter.
5. You see an installation instruction screen. Follow the instructions on the screen to install the utility on your computer's hard disk drive.
6. Once the utility is installed, log onto the directory you specified for the utility. Then type `EPCALIB` and press Enter to start the program.
7. You see the EPSON Print Head Alignment Utility main screen. Make sure your printer is listed on the screen and select Next.
8. Follow the instructions on the utility screens to align your print heads.



Note:
You can use a mouse with the utility if you have a DOS mouse driver installed.



Note:
Some tables contain the same characters for hex codes 00 to 7F as the PC437 table, so these samples list only characters for codes 80 to FF.

Selecting Character Tables

Most of the time you can select character tables using your application software. If you can't select them with your software, follow the instructions here to select one of the printer's internal character tables.

You can select a character table using default-setting mode (as described on page 5-3) or printer software commands (as described on page 5-17). Each character table is identified by the code shown beneath the sample, beginning on the next page.

| CODE | 0 | 1 | 2 | 3 | 4 | 5 | 6 | 7 | 8 | 9 | A | B | C | D | E | F |
|------|----|-----|---|---|---|---|---|---|---|---|---|---|---|---|---|---|
| 0 | ML | | | | | | | | | | | | | | | |
| 1 | | | | | | | | | | | | | | | | |
| 2 | | OC2 | | | | | | | | | | | | | | |
| 3 | | | | | | | | | | | | | | | | |
| 4 | | OC4 | | | | | | | | | | | | | | |
| 5 | | S | | | | | | | | | | | | | | |
| 6 | | | | | | | | | | | | | | | | |
| 7 | | | | | | | | | | | | | | | | |
| 8 | | | | | | | | | | | | | | | | |
| 9 | HT | DN | | | | | | | | | | | | | | |
| A | LF | | | | | | | | | | | | | | | |
| B | VT | ESC | | | | | | | | | | | | | | |
| C | FF | | | | | | | | | | | | | | | |
| D | CR | | | | | | | | | | | | | | | |
| E | SO | | | | | | | | | | | | | | | |
| F | SI | | | | | | | | | | | | | | | |

PC437 (U.S., Standard Europe)

| CODE | 8 | 9 | A | B | C | D | E | F |
|------|---|---|---|---|---|---|---|---|
| 0 | A | P | 1 | | L | ± | ω | ϒ |
| 1 | B | Σ | κ | | ⊥ | ⊥ | ó | ± |
| 2 | Γ | T | λ | | ⊥ | ⊥ | é | ± |
| 3 | Δ | Y | μ | | ⊥ | ⊥ | ñ | ± |
| 4 | E | Φ | ν | | ⊥ | ⊥ | ι | ± |
| 5 | Z | X | ξ | | ⊥ | ⊥ | í | ± |
| 6 | H | Ψ | ο | | ⊥ | ⊥ | ó | ± |
| 7 | Θ | Ω | π | | ⊥ | ⊥ | ú | ± |
| 8 | I | Κ | α | | ⊥ | ⊥ | ó | ± |
| 9 | A | Λ | β | | ⊥ | ⊥ | ω | ± |
| A | B | M | γ | | ⊥ | ⊥ | Α | ± |
| B | C | N | δ | | ⊥ | ⊥ | Ε | ± |
| C | D | O | ε | | ⊥ | ⊥ | Η | ± |
| D | E | Π | ζ | | ⊥ | ⊥ | Ι | ± |
| E | F | | η | | ⊥ | ⊥ | Υ | ± |
| F | | | θ | | ⊥ | ⊥ | | ± |

PC437 Greek (Greek)

| CODE | 8 | 9 | A | B | C | D | E | F |
|------|---|---|---|---|---|---|---|---|
| 0 | Ç | È | á | | L | ø | Ö | - |
| 1 | ù | æ | í | | ⊥ | ð | ö | ± |
| 2 | é | æ | ó | | ⊥ | ð | ö | ± |
| 3 | á | ö | ñ | | ⊥ | ð | ö | ± |
| 4 | ä | ö | ñ | | ⊥ | ð | ö | ± |
| 5 | à | ö | ñ | | ⊥ | ð | ö | ± |
| 6 | ä | ö | ñ | | ⊥ | ð | ö | ± |
| 7 | ç | ù | ý | | ⊥ | ÿ | ö | ± |
| 8 | è | é | ú | | ⊥ | ÿ | ö | ± |
| 9 | é | ú | û | | ⊥ | ÿ | ö | ± |
| A | è | í | ø | | ⊥ | ÿ | ö | ± |
| B | í | ø | é | | ⊥ | ÿ | ö | ± |
| C | í | ø | é | | ⊥ | ÿ | ö | ± |
| D | í | ø | é | | ⊥ | ÿ | ö | ± |
| E | í | ø | é | | ⊥ | ÿ | ö | ± |
| F | í | ø | é | | ⊥ | ÿ | ö | ± |

PC850 (Multilingual)

| CODE | 8 | 9 | A | B | C | D | E | F |
|------|---|---|---|---|---|---|---|---|
| 0 | Ç | È | á | | L | | Ö | - |
| 1 | Ü | È | í | | ⊥ | | ö | ± |
| 2 | é | ç | ó | | ⊥ | | ö | ± |
| 3 | á | ç | ó | | ⊥ | | ö | ± |
| 4 | ä | ç | ó | | ⊥ | | ö | ± |
| 5 | à | ç | ó | | ⊥ | | ö | ± |
| 6 | ä | ç | ó | | ⊥ | | ö | ± |
| 7 | ç | ù | ý | | ⊥ | | ö | ± |
| 8 | è | é | ú | | ⊥ | | ö | ± |
| 9 | é | ú | û | | ⊥ | | ö | ± |
| A | è | í | ø | | ⊥ | | ö | ± |
| B | í | ø | é | | ⊥ | | ö | ± |
| C | í | ø | é | | ⊥ | | ö | ± |
| D | í | ø | é | | ⊥ | | ö | ± |
| E | í | ø | é | | ⊥ | | ö | ± |
| F | í | ø | é | | ⊥ | | ö | ± |

PC853 (Turkish)

| CODE | 8 | 9 | A | B | C | D | E | F |
|------|---|---|---|---|---|---|---|---|
| 0 | ђ | џ | а | ⋮ | Л | Я | - | |
| 1 | Ђ | Љ | А | ⋮ | Л | Я | ы | |
| 2 | ѓ | љ | Б | ⋮ | М | Р | ы | |
| 3 | ђ | њ | Б | ⋮ | М | Р | з | |
| 4 | ѓ | њ | Ц | ⋮ | Н | С | з | |
| 5 | в | џ | Ц | ⋮ | Н | С | ш | |
| 6 | е | к | Д | ⋮ | О | Т | ш | |
| 7 | е | к | Д | ⋮ | О | Т | э | |
| 8 | с | р | Е | ⋮ | П | У | э | |
| 9 | с | р | Е | ⋮ | П | У | щ | |
| A | і | у | Ф | ⋮ | Р | Х | щ | |
| B | І | У | Ф | ⋮ | Р | Х | ч | |
| C | І | У | Ф | ⋮ | Р | Х | ч | |
| D | І | У | Ф | ⋮ | Р | Х | ч | |
| E | І | У | Ф | ⋮ | Р | Х | ч | |
| F | І | У | Ф | ⋮ | Р | Х | ч | |

PC855 (Cyrillic)

| CODE | 8 | 9 | A | B | C | D | E | F |
|------|---|---|---|---|---|---|---|---|
| 0 | ç | ü | á | ⋮ | Л | đ | ó | - |
| 1 | Ç | Ü | Á | ⋮ | Л | Đ | Ó | ˆ |
| 2 | ç | ü | í | ⋮ | Т | đ | ó | ˆ |
| 3 | ç | ü | í | ⋮ | Т | Đ | Ó | ˆ |
| 4 | ä | ö | ú | ⋮ | Т | đ | ó | ˆ |
| 5 | ä | ö | ú | ⋮ | Т | Đ | Ó | ˆ |
| 6 | ä | ö | ú | ⋮ | Т | đ | ó | ˆ |
| 7 | ä | ö | ú | ⋮ | Т | Đ | Ó | ˆ |
| 8 | ç | ü | í | ⋮ | Т | đ | ó | ˆ |
| 9 | Ç | Ü | Á | ⋮ | Т | Đ | Ó | ˆ |
| A | ç | ü | í | ⋮ | Т | đ | ó | ˆ |
| B | Ç | Ü | Á | ⋮ | Т | Đ | Ó | ˆ |
| C | ç | ü | í | ⋮ | Т | đ | ó | ˆ |
| D | Ç | Ü | Á | ⋮ | Т | Đ | Ó | ˆ |
| E | ç | ü | í | ⋮ | Т | đ | ó | ˆ |
| F | Ç | Ü | Á | ⋮ | Т | Đ | Ó | ˆ |

PC852 (East Europe)

| CODE | 8 | 9 | A | B | C | D | E | F |
|------|---|---|---|---|---|---|---|---|
| 0 | ç | ş | á | ⋮ | Л | Q | ó | - |
| 1 | Ç | Ş | Á | ⋮ | Л | Q | Ó | ˆ |
| 2 | ç | ş | í | ⋮ | Т | Q | ó | ˆ |
| 3 | ç | ş | í | ⋮ | Т | Q | Ó | ˆ |
| 4 | ä | ö | ú | ⋮ | Т | Q | ó | ˆ |
| 5 | ä | ö | ú | ⋮ | Т | Q | Ó | ˆ |
| 6 | ä | ö | ú | ⋮ | Т | Q | ó | ˆ |
| 7 | ç | ü | í | ⋮ | Т | Q | ó | ˆ |
| 8 | ç | ü | í | ⋮ | Т | Q | Ó | ˆ |
| 9 | ç | ü | í | ⋮ | Т | Q | ó | ˆ |
| A | ç | ü | í | ⋮ | Т | Q | Ó | ˆ |
| B | ç | ü | í | ⋮ | Т | Q | ó | ˆ |
| C | ç | ü | í | ⋮ | Т | Q | Ó | ˆ |
| D | ç | ü | í | ⋮ | Т | Q | ó | ˆ |
| E | ç | ü | í | ⋮ | Т | Q | Ó | ˆ |
| F | ç | ü | í | ⋮ | Т | Q | ó | ˆ |

PC857 (Turkish)

| CODE | 8 | 9 | A | B | C | D | E | F |
|------|---|---|---|---|---|---|---|---|
| 0 | ç | é | á | ⋮ | Л | Л | á | ± |
| 1 | Ç | É | Á | ⋮ | Л | Л | Á | ± |
| 2 | ç | é | í | ⋮ | Т | Л | á | ± |
| 3 | ç | é | í | ⋮ | Т | Л | Á | ± |
| 4 | ä | ö | ú | ⋮ | Т | Л | á | ± |
| 5 | ä | ö | ú | ⋮ | Т | Л | Á | ± |
| 6 | ä | ö | ú | ⋮ | Т | Л | á | ± |
| 7 | ç | é | í | ⋮ | Т | Л | Á | ± |
| 8 | ç | é | í | ⋮ | Т | Л | á | ± |
| 9 | ç | é | í | ⋮ | Т | Л | Á | ± |
| A | ç | é | í | ⋮ | Т | Л | á | ± |
| B | ç | é | í | ⋮ | Т | Л | Á | ± |
| C | ç | é | í | ⋮ | Т | Л | á | ± |
| D | ç | é | í | ⋮ | Т | Л | Á | ± |
| E | ç | é | í | ⋮ | Т | Л | á | ± |
| F | ç | é | í | ⋮ | Т | Л | Á | ± |

PC860 (Portuguese)

| CODE | B | 9 | A | B | C | D | E | F |
|------|---|---|---|---|---|---|---|---|
| 0 | Ç | È | Á | À | É | Ê | Ë | ± |
| 1 | Ù | Ê | Ó | Ë | Ì | Í | Î | ± |
| 2 | Ê | Ë | Ô | Ë | Ì | Í | Î | ± |
| 3 | Á | È | Û | Ë | Ì | Í | Î | ± |
| 4 | À | È | Ô | Ë | Ì | Í | Î | ± |
| 5 | À | È | Û | Ë | Ì | Í | Î | ± |
| 6 | À | È | Û | Ë | Ì | Í | Î | ± |
| 7 | À | È | Û | Ë | Ì | Í | Î | ± |
| 8 | À | È | Û | Ë | Ì | Í | Î | ± |
| 9 | À | È | Û | Ë | Ì | Í | Î | ± |
| A | À | È | Û | Ë | Ì | Í | Î | ± |
| B | À | È | Û | Ë | Ì | Í | Î | ± |
| C | À | È | Û | Ë | Ì | Í | Î | ± |
| D | À | È | Û | Ë | Ì | Í | Î | ± |
| E | À | È | Û | Ë | Ì | Í | Î | ± |
| F | À | È | Û | Ë | Ì | Í | Î | ± |

PC863 (Canadian-French)

| CODE | B | 9 | A | B | C | D | E | F |
|------|---|---|---|---|---|---|---|---|
| 0 | Ç | È | Á | À | É | Ê | Ë | ± |
| 1 | Ù | Ê | Ó | Ë | Ì | Í | Î | ± |
| 2 | Ê | Ë | Ô | Ë | Ì | Í | Î | ± |
| 3 | Á | È | Û | Ë | Ì | Í | Î | ± |
| 4 | À | È | Ô | Ë | Ì | Í | Î | ± |
| 5 | À | È | Û | Ë | Ì | Í | Î | ± |
| 6 | À | È | Û | Ë | Ì | Í | Î | ± |
| 7 | À | È | Û | Ë | Ì | Í | Î | ± |
| 8 | À | È | Û | Ë | Ì | Í | Î | ± |
| 9 | À | È | Û | Ë | Ì | Í | Î | ± |
| A | À | È | Û | Ë | Ì | Í | Î | ± |
| B | À | È | Û | Ë | Ì | Í | Î | ± |
| C | À | È | Û | Ë | Ì | Í | Î | ± |
| D | À | È | Û | Ë | Ì | Í | Î | ± |
| E | À | È | Û | Ë | Ì | Í | Î | ± |
| F | À | È | Û | Ë | Ì | Í | Î | ± |

PC865 (Norwegian)

| CODE | B | 9 | A | B | C | D | E | F |
|------|---|---|---|---|---|---|---|---|
| 0 | А | Р | а | б | в | г | д | е |
| 1 | Б | С | б | в | г | д | е | с |
| 2 | В | Т | в | г | д | е | с | т |
| 3 | Г | У | г | д | е | с | т | у |
| 4 | Д | Ф | д | е | с | т | у | ф |
| 5 | Е | Х | е | с | т | у | ф | х |
| 6 | Ж | Ц | ж | ц | ч | ш | щ | з |
| 7 | З | Ч | з | ц | ч | ш | щ | ж |
| 8 | И | Ш | и | ш | щ | з | ж | и |
| 9 | Я | Щ | я | щ | з | ж | и | я |
| A | К | Ъ | к | ъ | ь | ы | ь | к |
| B | Л | Ы | л | ы | ь | ы | ь | л |
| C | М | Ь | м | ь | ы | ь | ы | м |
| D | Н | Э | н | э | ю | я | ю | н |
| E | О | Ю | о | ю | я | ю | я | о |
| F | П | Я | п | я | ю | я | ю | п |

PC866 (Russian)

| CODE | B | 9 | A | B | C | D | E | F |
|------|---|---|---|---|---|---|---|---|
| 0 | Ç | È | Á | À | É | Ê | Ë | ± |
| 1 | Ù | Ê | Ó | Ë | Ì | Í | Î | ± |
| 2 | Ê | Ë | Ô | Ë | Ì | Í | Î | ± |
| 3 | Á | È | Û | Ë | Ì | Í | Î | ± |
| 4 | À | È | Ô | Ë | Ì | Í | Î | ± |
| 5 | À | È | Û | Ë | Ì | Í | Î | ± |
| 6 | À | È | Û | Ë | Ì | Í | Î | ± |
| 7 | À | È | Û | Ë | Ì | Í | Î | ± |
| 8 | À | È | Û | Ë | Ì | Í | Î | ± |
| 9 | À | È | Û | Ë | Ì | Í | Î | ± |
| A | À | È | Û | Ë | Ì | Í | Î | ± |
| B | À | È | Û | Ë | Ì | Í | Î | ± |
| C | À | È | Û | Ë | Ì | Í | Î | ± |
| D | À | È | Û | Ë | Ì | Í | Î | ± |
| E | À | È | Û | Ë | Ì | Í | Î | ± |
| F | À | È | Û | Ë | Ì | Í | Î | ± |

PC861 (Icelandic)

Using Your Printer with DOS

| CODE | 8 | 9 | A | B | C | D | E | F |
|------|---|---|---|---|---|---|---|---|
| 0 | | Ι | Υ | ⋮ | Λ | Τ | Ζ | - |
| 1 | | Υ | Υ | ⋮ | ⊥ | Υ | η | ± |
| 2 | | Ο | Ο | ⋮ | ⊥ | Θ | θ | υ |
| 3 | | | Α | ⋮ | ⊥ | Χ | φ | φ |
| 4 | | | Β | ⋮ | ⊥ | Ψ | κ | χ |
| 5 | | Υ | Β | ⋮ | ⊥ | Ω | λ | ξ |
| 6 | λ | Υ | Γ | ⋮ | ⊥ | α | μ | ψ |
| 7 | | ϑ | Δ | ⋮ | ⊥ | β | ν | * |
| 8 | | ϑ | Ε | ⋮ | ⊥ | γ | ε | · |
| 9 | | · | Ζ | ⋮ | ⊥ | δ | ο | ω |
| A | | · | Η | ⋮ | ⊥ | ε | π | ϖ |
| B | | · | Θ | ⋮ | ⊥ | ϛ | ρ | ϖ |
| C | | · | Ι | ⋮ | ⊥ | ϛ | σ | ϖ |
| D | | · | Κ | ⋮ | ⊥ | ϛ | τ | ϖ |
| E | | · | Λ | ⋮ | ⊥ | ϛ | υ | ϖ |
| F | | · | Μ | ⋮ | ⊥ | ϛ | φ | ϖ |

PC869 (Greek)

| CODE | 8 | 9 | A | B | C | D | E | F |
|------|----|-----|---|---|---|---|---|---|
| 0 | | NUL | | * | À | Ð | á | ð |
| 1 | | | | ± | Á | Ñ | â | ñ |
| 2 | | DC2 | ç | * | Â | Ò | ã | ó |
| 3 | | | ê | * | Ã | Ó | ä | ô |
| 4 | | DC4 | ë | * | Ä | Ô | å | õ |
| 5 | | | µ | * | Å | Õ | æ | ö |
| 6 | | | ¶ | * | Æ | Ö | ç | ö |
| 7 | | | § | * | Ç | Ø | è | ø |
| 8 | | | · | * | È | Θ | é | ø |
| 9 | HT | EM | e | * | É | Ù | ê | ù |
| A | LF | | ø | * | Ê | Ú | ë | ú |
| B | VT | ESC | » | * | Ë | Û | ì | û |
| C | FF | | » | * | Ì | Ü | í | ü |
| D | CR | | » | * | Í | Ý | î | ý |
| E | SO | | » | * | Î | Þ | ï | þ |
| F | SI | | » | * | Ï | ß | í | ÿ |

BRASCI (Brazilian, Portuguese)

| CODE | 8 | 9 | A | B | C | D | E | F |
|------|----|-----|---|---|---|---|-----|---|
| 0 | | NUL | | Ô | ì | ò | | |
| 1 | | | À | Ó | á | ó | | |
| 2 | | DC2 | À | Ô | â | ô | | |
| 3 | | | Ã | Õ | ã | õ | | |
| 4 | | DC4 | Ã | Ö | ä | ö | | |
| 5 | | | Ç | Ø | ç | ø | | |
| 6 | | | È | Ù | é | ú | | |
| 7 | | | É | Ú | ê | û | | |
| 8 | | | Ê | Û | ë | ü | | |
| 9 | HT | EM | Ë | Ü | ì | ý | | |
| A | LF | | Ë | Ý | î | þ | | |
| B | VT | ESC | Ì | Þ | ï | ß | | |
| C | FF | | Í | ß | í | ÿ | | |
| D | CR | | Í | · | î | · | | |
| E | SO | | Î | · | ï | · | | |
| F | SI | | Ï | · | ð | · | DEL | |

Abicom (Brazilian, Portuguese)

| HexCode | 0 | 1 | 2 | 3 | 4 | 5 | 6 | 7 | 8 | 9 | A | B | C | D | E | F |
|---------|---|---|---|---|---|---|---|---|---|---|---|---|---|---|---|---|
| 0 | | | 0 | @ | P | * | p | | | | À | Á | Â | Ã | Ä | Å |
| 1 | | 1 | 1 | A | Q | a | q | | | | Ä | Å | Æ | Ç | È | É |
| 2 | | | 2 | B | R | b | r | | | | È | É | Ê | Ë | Ì | Í |
| 3 | | | 3 | C | S | c | s | | | | Ê | Ë | Ì | Í | Î | Ï |
| 4 | | | 4 | D | T | d | t | | | | Ë | Ì | Í | Î | Ï | Ð |
| 5 | | | 5 | E | U | e | u | | | | Ï | Ð | Ñ | Ò | Ó | Ô |
| 6 | | | 6 | F | V | f | v | | | | Ò | Ó | Ô | Õ | Ö | × |
| 7 | | | 7 | G | W | g | w | | | | Ó | Ô | Õ | Ö | × | Ù |
| 8 | | | 8 | H | X | h | x | | | | Ô | Õ | Ö | × | Ù | Ú |
| 9 | | | 9 | I | Y | i | y | | | | Õ | Ö | × | Ù | Ú | Û |
| A | | | | J | Z | j | z | | | | Ö | × | Ù | Ú | Û | Ü |
| B | | | | K | [| k | [| | | | × | Ù | Ú | Û | Ü | Ý |
| C | | | | L | \ | l | \ | | | | Ù | Ú | Û | Ü | Ý | Þ |
| D | | | | M |] | m |] | | | | Ú | Û | Ü | Ý | Þ | ß |
| E | | | | N | ^ | n | ^ | | | | Û | Ü | Ý | Þ | ß | à |
| F | | | | O | _ | o | _ | | | | Ü | Ý | Þ | ß | à | á |

Roman 8

| CODE | 8 | 9 | A | B | C | D | E | F |
|------|---|---|---|---|---|---|---|---|
| 0 | | | " | λ | Ð | à | ø | |
| 1 | | : | ± | À | Ñ | á | ñ | |
| 2 | | ; | ± | Á | Ò | â | ò | |
| 3 | | ! | ± | Â | Ó | ã | ó | |
| 4 | | ! | ± | Ã | Ô | ä | ô | |
| 5 | | ! | ± | Ä | Õ | å | ö | |
| 6 | | ! | ± | Å | Ö | æ | ø | |
| 7 | | ! | ± | Æ | × | ç | ÷ | |
| 8 | | ! | ± | Ç | Ø | è | ù | |
| 9 | | ! | ± | È | Ù | é | ú | |
| A | | ! | ± | É | Ú | ê | û | |
| B | | ! | ± | Ê | Û | ë | ü | |
| C | | ! | ± | Ë | Ü | ì | ý | |
| D | | ! | ± | Ì | Ý | í | ÿ | |
| E | | ! | ± | Í | Þ | î | | |
| F | | ! | ± | Î | ß | ï | | |

ISO Latin 1

| CODE | 8 | 9 | A | B | C | D | E | F |
|------|---|---|---|---|---|---|---|---|
| 0 | Ç | È | É | Ê | Ë | Ì | Í | Î |
| 1 | Û | Ü | Ý | Þ | ß | à | á | â |
| 2 | ê | ë | ì | í | î | ï | ð | ñ |
| 3 | ä | å | ö | ÷ | ø | ù | ú | û |
| 4 | ä | å | ö | ÷ | ø | ù | ú | û |
| 5 | ä | å | ö | ÷ | ø | ù | ú | û |
| 6 | ä | å | ö | ÷ | ø | ù | ú | û |
| 7 | ä | å | ö | ÷ | ø | ù | ú | û |
| 8 | ä | å | ö | ÷ | ø | ù | ú | û |
| 9 | ä | å | ö | ÷ | ø | ù | ú | û |
| A | ä | å | ö | ÷ | ø | ù | ú | û |
| B | ä | å | ö | ÷ | ø | ù | ú | û |
| C | ä | å | ö | ÷ | ø | ù | ú | û |
| D | ä | å | ö | ÷ | ø | ù | ú | û |
| E | ä | å | ö | ÷ | ø | ù | ú | û |
| F | ä | å | ö | ÷ | ø | ù | ú | û |

MAZOWIA (Poland)

| CODE | 8 | 9 | A | B | C | D | E | F |
|------|---|---|---|---|---|---|---|---|
| 0 | Ç | È | É | Ê | Ë | Ì | Í | Î |
| 1 | Û | Ü | Ý | Þ | ß | à | á | â |
| 2 | ê | ë | ì | í | î | ï | ð | ñ |
| 3 | ä | å | ö | ÷ | ø | ù | ú | û |
| 4 | ä | å | ö | ÷ | ø | ù | ú | û |
| 5 | ä | å | ö | ÷ | ø | ù | ú | û |
| 6 | ä | å | ö | ÷ | ø | ù | ú | û |
| 7 | ä | å | ö | ÷ | ø | ù | ú | û |
| 8 | ä | å | ö | ÷ | ø | ù | ú | û |
| 9 | ä | å | ö | ÷ | ø | ù | ú | û |
| A | ä | å | ö | ÷ | ø | ù | ú | û |
| B | ä | å | ö | ÷ | ø | ù | ú | û |
| C | ä | å | ö | ÷ | ø | ù | ú | û |
| D | ä | å | ö | ÷ | ø | ù | ú | û |
| E | ä | å | ö | ÷ | ø | ù | ú | û |
| F | ä | å | ö | ÷ | ø | ù | ú | û |

Code MJK (CSFR)

| CODE | 8 | 9 | A | B | C | D | E | F |
|------|---|---|---|---|---|---|---|---|
| 0 | | | " | λ | Ð | à | ø | |
| 1 | | : | ± | À | Ñ | á | ñ | |
| 2 | | ; | ± | Á | Ò | â | ò | |
| 3 | | ! | ± | Â | Ó | ã | ó | |
| 4 | | ! | ± | Ã | Ô | ä | ô | |
| 5 | | ! | ± | Ä | Õ | å | ö | |
| 6 | | ! | ± | Å | Ö | æ | ø | |
| 7 | | ! | ± | Æ | × | ç | ÷ | |
| 8 | | ! | ± | Ç | Ø | è | ù | |
| 9 | | ! | ± | È | Ù | é | ú | |
| A | | ! | ± | É | Ú | ê | û | |
| B | | ! | ± | Ê | Û | ë | ü | |
| C | | ! | ± | Ë | Ü | ì | ý | |
| D | | ! | ± | Ì | Ý | í | ÿ | |
| E | | ! | ± | Í | Þ | î | | |
| F | | ! | ± | Î | ß | ï | | |

ISO 8859-7 (Latin/Greek)

| CODE | 8 | 9 | A | B | C | D | E | F |
|------|---|---|---|---|---|---|---|---|
| 0 | | | | * | À | Á | Â | Ë |
| 1 | | | ı | ± | Ä | Å | Ä | Ë |
| 2 | | | ç | ² | À | Á | Â | Ë |
| 3 | | | ƒ | ' | À | Á | Â | Ë |
| 4 | | | ı | ı | À | Á | Â | Ë |
| 5 | | | ı | ı | À | Á | Â | Ë |
| 6 | | | ı | ı | À | Á | Â | Ë |
| 7 | | | ı | ı | À | Á | Â | Ë |
| 8 | | | ı | ı | À | Á | Â | Ë |
| 9 | | | ı | ı | À | Á | Â | Ë |
| A | | | ı | ı | À | Á | Â | Ë |
| B | | | ı | ı | À | Á | Â | Ë |
| C | | | ı | ı | À | Á | Â | Ë |
| D | | | ı | ı | À | Á | Â | Ë |
| E | | | ı | ı | À | Á | Â | Ë |
| F | | | ı | ı | À | Á | Â | Ë |

ISO Latin 1T (Turkish)

| CODE | 8 | 9 | A | B | C | D | E | F |
|------|---|---|---|---|---|---|---|---|
| 0 | А | Р | а | р | Л | л | а | ± |
| 1 | В | С | б | с | Г | г | В | ± |
| 2 | Г | Т | г | т | Д | д | Г | ± |
| 3 | Д | У | д | у | Е | е | Д | ± |
| 4 | Е | Ф | е | ф | Ж | ж | Е | ± |
| 5 | Ж | Ц | ж | ц | З | з | Ж | ± |
| 6 | З | Ч | з | ч | И | и | З | ± |
| 7 | И | Щ | и | щ | Й | й | И | ± |
| 8 | Й | Ъ | й | ъ | К | к | Й | ± |
| 9 | К | Ы | к | ы | Л | л | К | ± |
| A | Л | Ь | л | ь | М | м | Л | ± |
| B | М | Э | м | э | Н | н | М | ± |
| C | Н | Ю | н | ю | О | о | Н | ± |
| D | О | Я | о | я | П | п | О | ± |
| E | | | | | | | | |
| F | | | | | | | | |

Bulgaria (Bulgaria)

| CODE | 8 | 9 | A | B | C | D | E | F |
|------|---|---|---|---|---|---|---|---|
| 0 | Ç | É | Á | À | À | À | À | ± |
| 1 | Ü | Æ | Í | À | À | À | À | ± |
| 2 | É | Æ | Ó | À | À | À | À | ± |
| 3 | À | À | À | À | À | À | À | ± |
| 4 | À | À | À | À | À | À | À | ± |
| 5 | À | À | À | À | À | À | À | ± |
| 6 | À | À | À | À | À | À | À | ± |
| 7 | Ç | Ü | À | À | À | À | À | ± |
| 8 | É | Ü | À | À | À | À | À | ± |
| 9 | É | Ü | À | À | À | À | À | ± |
| A | É | Ü | À | À | À | À | À | ± |
| B | É | Ü | À | À | À | À | À | ± |
| C | É | Ü | À | À | À | À | À | ± |
| D | É | Ü | À | À | À | À | À | ± |
| E | É | Ü | À | À | À | À | À | ± |
| F | É | Ü | À | À | À | À | À | ± |

PC774 (LST 1283:1993)

| CODE | 8 | 9 | A | B | C | D | E | F |
|------|---|---|---|---|---|---|---|---|
| 0 | Ç | É | Á | À | À | À | À | ± |
| 1 | Ü | Æ | Í | À | À | À | À | ± |
| 2 | É | Æ | Ó | À | À | À | À | ± |
| 3 | À | À | À | À | À | À | À | ± |
| 4 | À | À | À | À | À | À | À | ± |
| 5 | À | À | À | À | À | À | À | ± |
| 6 | À | À | À | À | À | À | À | ± |
| 7 | Ç | Ü | À | À | À | À | À | ± |
| 8 | É | Ü | À | À | À | À | À | ± |
| 9 | É | Ü | À | À | À | À | À | ± |
| A | É | Ü | À | À | À | À | À | ± |
| B | É | Ü | À | À | À | À | À | ± |
| C | É | Ü | À | À | À | À | À | ± |
| D | É | Ü | À | À | À | À | À | ± |
| E | É | Ü | À | À | À | À | À | ± |
| F | É | Ü | À | À | À | À | À | ± |

Estonia (Estonia)

| CODE | 8 | 9 | A | B | C | D | E | F |
|------|---|---|---|---|---|---|---|---|
| 0 | | | | | | | | |
| 1 | | | À | Á | Â | Ã | Ä | Å |
| 2 | | | Ä | Å | Æ | Ç | È | É |
| 3 | | | È | É | Ê | Ë | Ì | Í |
| 4 | | | Ì | Í | Î | Ï | Ð | Ñ |
| 5 | | | Ñ | Ò | Ó | Ô | Õ | Ö |
| 6 | | | Ö | × | Ø | Ù | Ú | Û |
| 7 | | | Û | Ü | Ý | Þ | ß | à |
| 8 | | | à | á | â | ã | ä | å |
| 9 | | | å | æ | ç | è | é | ê |
| A | | | ê | ë | ì | í | î | ï |
| B | | | ï | ð | ñ | ò | ó | ô |
| C | | | ô | õ | ö | ÷ | ø | ù |
| D | | | ù | ú | û | ü | ý | þ |
| E | | | þ | ß | à | á | â | ã |
| F | | | ã | ä | å | æ | ç | è |

ISO 8859-2

| CODE | 8 | 9 | A | B | C | D | E | F |
|------|---|---|---|---|---|---|---|---|
| 0 | À | Á | Â | Ã | Ä | Å | Æ | Ç |
| 1 | Ä | Å | Æ | Ç | È | É | Ê | Ë |
| 2 | È | É | Ê | Ë | Ì | Í | Î | Ï |
| 3 | Ì | Í | Î | Ï | Ð | Ñ | Ò | Ó |
| 4 | Ñ | Ò | Ó | Ô | Õ | Ö | × | Ø |
| 5 | Ø | Ù | Ú | Û | Ü | Ý | Þ | ß |
| 6 | ß | à | á | â | ã | ä | å | æ |
| 7 | æ | ç | è | é | ê | ë | ì | í |
| 8 | ì | í | î | ï | ð | ñ | ò | ó |
| 9 | ò | ó | ô | õ | ö | ÷ | ø | ù |
| A | ù | ú | û | ü | ý | þ | ß | à |
| B | à | á | â | ã | ä | å | æ | ç |
| C | ã | ä | å | æ | ç | è | é | ê |
| D | è | é | ê | ë | ì | í | î | ï |
| E | ì | í | î | ï | ð | ñ | ò | ó |
| F | ò | ó | ô | õ | ö | ÷ | ø | ù |

PC866 LAT (Latvian)

| CODE | 8 | 9 | A | B | C | D | E | F |
|------|-----|-----|----|---|---|---|---|---|
| 0 | NUL | | 0 | @ | P | | p | |
| 1 | | ! | 1 | A | Q | a | q | |
| 2 | | DC2 | " | 2 | B | R | b | r |
| 3 | | # | 3 | C | S | c | s | |
| 4 | | DC4 | \$ | 4 | D | T | d | t |
| 5 | | % | 5 | E | U | e | u | |
| 6 | | & | 6 | F | V | f | v | |
| 7 | | ' | 7 | G | W | g | w | |
| 8 | | (| 8 | H | X | h | x | |
| 9 | HT | EM |) | 9 | I | Y | i | y |
| A | LF | | * | : | J | Z | j | z |
| B | VT | ESC | + | ; | K | [| k | { |
| C | FF | | , | < | L | \ | l | ; |
| D | CR | | - | = | M |] | m | } |
| E | SO | | . | > | N | ^ | n | ~ |
| F | SI | | / | ? | O | _ | o | |

Italic

No characters are available for hex code 15 in the italic character table.

International Character Sets

You can select one of these international character sets using default-setting mode (as described on page 5-3) or the ESC R command (as described on page 5-17). When you select a character set, such as Italic France, the characters in the France row on the table below are used in the italic character table.

You can select one of these eight international character sets using default-setting mode or ESC R.

| Country | ASCII code hex | | | | | | | | | | | |
|---------|----------------|----|----|----|----|----|----|----|----|----|----|----|
| | 23 | 24 | 40 | 5B | 5C | 5D | 5E | 60 | 7B | 7C | 7D | 7E |
| USA | # | \$ | @ | [| \ |] | ^ | ' | { | | } | - |
| France | # | \$ | à | ° | ç | § | ^ | ' | é | ù | è | ¨ |
| Germany | # | \$ | § | À | Ö | Ü | ^ | ' | ä | ö | ü | ß |
| UK | £ | \$ | @ | [| \ |] | ^ | ' | { | | } | - |
| Denmark | # | \$ | @ | Æ | Ø | Å | ^ | ' | æ | ø | å | - |
| Sweden | # | ¤ | É | À | Ö | Å | Ü | é | ä | ö | å | ü |
| Italy | # | \$ | @ | ° | \ | é | ^ | ù | à | ò | è | ì |
| Spain | ¤ | \$ | @ | í | Ñ | ¿ | ^ | ' | ñ | õ | ü | - |

You can select one of these seven sets using ESC R only.

| Country | ASCII code hex | | | | | | | | | | | |
|---------------|----------------|----|----|----|----|----|----|----|----|----|----|----|
| | 23 | 24 | 40 | 5B | 5C | 5D | 5E | 60 | 7B | 7C | 7D | 7E |
| Japan | # | \$ | @ | [| ¥ |] | ^ | ' | { | | } | - |
| Norway | # | ¤ | É | Æ | Ø | Å | Ü | é | æ | ø | å | ü |
| Denmark II | # | \$ | É | Æ | Ø | Å | Ü | é | æ | ø | å | ü |
| Spain II | # | \$ | á | í | Ñ | ¿ | é | ' | í | ñ | ó | ú |
| Latin America | # | \$ | á | í | Ñ | ¿ | é | ü | í | ñ | ó | ú |
| Korea | # | \$ | @ | [| ₩ |] | ^ | ' | { | | } | - |
| Legal | # | \$ | § | ° | ' | ¨ | ¶ | ' | © | ® | † | ™ |

Characters Available with the ESC (^ Command

To print with the characters listed below, use the ESC (^ command as described in the next section.

| CODE | 0 | 1 | 7 |
|------|---|----|---|
| 0 | | | ▶ |
| 1 | ◉ | ◄ | |
| 2 | ⊙ | ⊚ | |
| 3 | ▼ | !! | |
| 4 | ⊕ | ⊖ | |
| 5 | ⊕ | | |
| 6 | ⊕ | — | |
| 7 | · | ⊚ | ↑ |
| 8 | ■ | | ↑ |
| 9 | ◉ | ↓ | |
| A | ■ | → | |
| B | ♠ | ← | |
| C | ♠ | ↖ | |
| D | ♠ | ↗ | |
| E | ♠ | ↘ | |
| F | ◉ | ▼ | △ |

Using Printer Commands

You can operate your printer by using commands in one of two control code modes. For the best font and graphics control, always use EPSON ESC/P 2 mode. (For details on using ESC/P 2, see the *ESC/P Reference Manual* available from EPSON.)

If you need to emulate an IBM Proprinter, select IBM XL24E mode. (See IBM's X24/X24E reference manual.)

ESC/P 2 Control Codes

General operation:

ESC @, ESC U, ESC EM

Paper feeding:

CR, FF, LF, ESC 0, ESC 2, ESC 3, ESC +

Page format:

ESC (C, ESC C, ESC C 0, ESC Q, ESC I, ESC (c,
ESC N, ESC O

Print position motion:

ESC S, ESC \, ESC (V, ESC (v, ESC D, HT, ESC B,
ESC J, VT

Font selection:

ESC k, ESC x, ESC X, ESC P, ESC M, ESC g, ESC p,
ESC 4, ESC 5, ESC E, ESC F, ESC !

Font enhancement:

ESC W, DC 4, SO, DC2, SI, ESC w, ESC G, ESC H,
ESC T, ESC S, ESC -, ESC (-, ESC q

Spacing:

ESC SP, ESC c, ESC (U

Character handling:

ESC t, ESC (t, ESC R, ESC %, ESC &, ESC :, ESC 6,
ESC 7, ESC (^

Bit image:

ESC *

Graphics:

ESC (G, ESC ., ESC (e, ESC (i, ESC (\, ESC (s

Color:

ESC r, ESC (r

Printing mode:

ESC (K

IBM XL24E Emulation Control Codes

In the following commands, “(AGM)” indicates Alternate Graphics Mode commands. Do not type these characters as part of the command.

General operation:

NUL, DC3, ESC j, BEL, CAN, DC1, ESC Q, ESC [K,
ESC U

Paper feeding:

FF, LF, ESC 5, ESC A, ESC A (AGM), ESC 0, ESC 1,
ESC 2, ESC 3, ESC 3 (AGM), CR

Page format:

ESC C, ESC X, ESC N, ESC O, ESC 4

Print position motion:

ESC d, ESC R, ESC D, HT, ESC B, VT, ESC J,
ESC J (AGM)

Font selection:

DC2, ESC P, ESC :, ESC E, ESC F, ESC I

Font enhancement:

DC4, SO, ESC SO, ESC W, ESC [@, SI, ESC SI, ESC G,
ESC H, ESC T, ESC S, ESC -, ESC _

Spacing:

BS, SP, ESC [\

Character handling:

ESC 6, ESC 7, ESC [T, ESC ^, ESC \

Bit image:

ESC K, ESC L, ESC Y, ESC Z, ESC [g, ESC * (AGM)

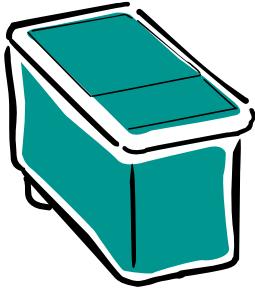

6

Maintenance and Transportation

It's easy to keep your EPSON Stylus COLOR 1520 printer working at its best. All you have to do is follow the simple instructions in this chapter for replacing ink cartridges, performing routine maintenance, and moving the printer.

This chapter covers the following procedures:

- ▶ Cleaning the print heads
- ▶ Replacing an ink cartridge
- ▶ Aligning the print heads
- ▶ Cleaning the printer
- ▶ Transporting the printer

Cleaning the Print Heads

If your printed image is unexpectedly light or faint, or dots are missing from the image, you may need to clean the print heads. This unclogs the nozzles so they can deliver ink properly.

Cleaning the print heads uses ink, so clean them only if print quality declines. You can use either of the following to clean the print heads:

- ▶ The Head Cleaning utility in your printer software (when your printer is connected directly to your computer)
- ▶ The printer's control panel buttons (when you're using DOS, or your printer is connected via an optional network interface card, or you don't want to use the Head Cleaning utility)



Note:
If either Ink Out light is flashing or on, you need to replace the ink cartridge instead. See page 6-4 for instructions.

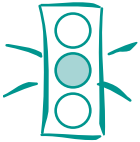



Caution:
Never turn off the printer while the Pause light is flashing.

If, however, the Pause light is still flashing after 10 minutes and the printer is not moving or making noise, you may turn off the printer.

Using the Head Cleaning Utility

Follow these steps to run the utility from a Windows or a Macintosh computer connected directly to the printer:

1. Make sure the printer is turned on but not printing.
2. To clean the black print head, make sure the Ink Out  light is off. To clean the color print head, make sure the Ink Out  light is off.
3. Access the Main printer settings dialog box as described in Chapter 1.
4. Click the Utility tab (Windows) or the Utility button (Macintosh). You see the Utility menu.
5. Click the Head Cleaning icon.
6. Follow the instructions on the screen to clean the print heads. Cleaning each head takes about two minutes, during which the printer makes some noise and the Pause light flashes.

When the Pause light stops flashing, you need to run a nozzle check to test the print quality and reset the cleaning cycle.
7. Make sure paper is loaded in the printer and click Print nozzle check pattern (Windows) or Confirmation (Macintosh), and then click Next. See page 6-4 for instructions on examining the nozzle check pattern.

If your print quality has not improved, repeat the steps above. If you don't notice any improvement after doing this two or three times, check the print quality solutions in Chapter 7.







Note:
If either Ink Out light is flashing or on, you need to replace the ink cartridge instead. See page 6-4 for instructions.



Caution:
Never turn off the printer while the Pause light is flashing.

If, however, the Pause light is still flashing after 10 minutes and the printer is not moving or making noise, you may turn off the printer.

Using the Control Panel

1. Make sure the printer is turned on and not printing.
2. To clean the black print head, make sure the Ink Out  light is off. To clean the color print head, make sure the Ink Out  light is off.
3. Press the Pause button. The Pause light comes on.
4. To clean the black print head, press the Alt and Cleaning  buttons. Or, to clean the color print head, press the Alt and Cleaning  buttons.

Cleaning each head takes about two minutes, during which the printer makes some noise and the Pause light flashes.

5. After the cleaning cycle is complete and the Pause light stays on without flashing, you can repeat step 4 to clean the other print head, if you wish.
6. When you're finished cleaning the print heads, press the Pause button to turn off the Pause light.
7. Now you need to print a page to test the print quality and reset the cleaning cycle. If you're using DOS or a network interface card, open an application and print a document containing black and color data. Then go to step 10.

If you're connected directly to the printer, run a nozzle check. Go to step 8.
8. Access the Main printer settings dialog box as described in Chapter 1. Then click the Utility tab (Windows) or the Utility button (Macintosh). You see the Utility menu.
9. Click the Nozzle Check icon, then click Next. See page 6-4 for instructions on examining the nozzle check.
10. If your print quality has not improved, repeat the steps above. If there's no improvement after doing this two or three times, check the print quality solutions in Chapter 7.

Examining the Nozzle Check Pattern

Examine the nozzle check pattern you print. It should look something like this, with the lower pattern colored cyan, magenta, and yellow:



W02271 C01267

Each staggered horizontal and straight vertical line should be complete, with no gaps in the dot pattern. If your printout looks okay, you're done. If any dots are missing, clean the print heads again, as explained in the previous sections.

Replacing an Ink Cartridge



Caution:
For best results, don't replace an ink cartridge unless its Ink Out light is flashing or on.

To ensure good results, use genuine EPSON cartridges and do not refill them. Other products may cause damage to your printer not covered by EPSON's warranty.

When an Ink Out light flashes, the indicated cartridge is low on ink. This is a good time to make sure you have a new cartridge. When the light stays on, the cartridge is empty and you need to replace it.

If your color ink cartridge runs out of ink, you can continue printing in black ink. See page 6-7 for instructions.

Use these EPSON ink cartridges within six months of installing them and before the expiration date on the package:

Black ink cartridge S020108

Color ink cartridge S020089

When you need new ink cartridges, contact your dealer or call EPSON Accessories at (800) 873-7766 (U.S. only). In Canada, please call (800) 873-7766 for dealer referral.





Caution:

To avoid damaging the printer, never move the print heads by hand.

Once you remove an ink cartridge, it becomes unusable and cannot be reinstalled.

You must completely remove the yellow tape seal from the top of the cartridge; leaving any portion of it on will permanently damage the cartridge. Do not remove the clear seal from the bottom of the cartridge; ink will leak out.

Removing and Installing an Ink Cartridge

You should replace an ink cartridge only when the Ink Out  or Ink Out  light is flashing or on. However, if you need to replace an outdated cartridge, you can do so before its Ink Out light comes on.

1. Make sure the printer is turned on and not printing.
2. Open the printer cover. The Cover Open and Pause lights come on.
3. Remove the new ink cartridge from its packaging. Then completely remove the yellow portion of the tape seal as shown:

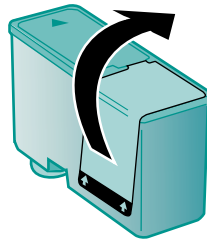

black cartridge

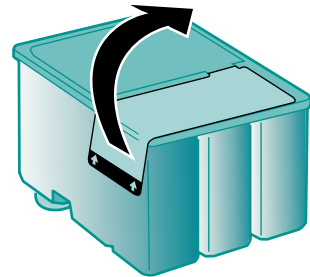

color cartridge

4. Hold down the Alt button on the printer's control panel for about three seconds.

The print heads move slightly left and the Pause light begins flashing. (The print heads return to their home position if you don't proceed to step 5 within 60 seconds.)

5. Pull up the ink cartridge clamp for the cartridge you need to replace. The cartridge rises up from its holder.



Warning:
If ink gets on your hands, wash them thoroughly with soap and water. If ink gets into your eyes, flush them immediately with water.

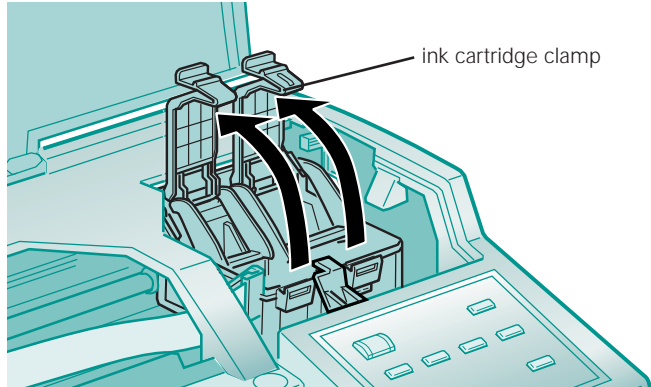

6. Lift the cartridge out of the printer and dispose of it carefully.
7. Lower the new ink cartridge into its holder with the label facing up and the arrow pointing to the back of the printer. The larger cartridge (color) goes on the right, the black ink cartridge on the left.



Caution:
Don't open the clamp or remove a cartridge except to replace it with a new one. Once you remove a cartridge, you can't reuse it, even if it contains ink.

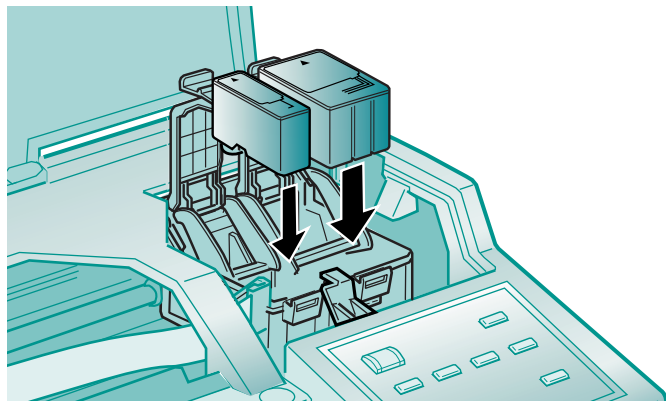

8. Press down the ink cartridge clamp until it locks in place.
9. Press the Alt button and close the printer cover.

The printer moves the print heads and begins charging the ink delivery system. (Even if you don't press the button, ink charging begins 60 seconds after you close the clamp.)

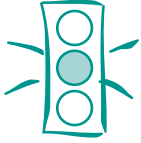

Caution:
Never turn off the printer while the Pause light is flashing.

If, however, the Pause light is still flashing after 10 minutes and the printer is not moving or making noise, you may turn off the printer.

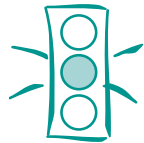

Caution:
If you're printing on continuous label paper, don't press Load/Eject; this feeds the paper backward and may cause labels to tear off inside the printer. Follow the steps on page 3-18 instead.

The Pause light flashes and the printer makes various sounds. Charging takes about several minutes, depending on whether you replaced one or both cartridges.

When it's finished, the Pause light stays on; press the Pause button to turn it off and resume printing.

Printing in Black Ink with an Empty Color Cartridge

If your color ink cartridge runs out of ink and the Ink Out  light comes on, you can still continue printing with black ink. (If the black ink cartridge runs out of ink, you cannot continue printing.) However, you will need to resend any print job you were printing when the color ink ran out. Follow these steps:

1. Turn off the printer.
2. Wait about five seconds and then turn the printer back on again. **Don't remove the empty color ink cartridge.**
3. Press the Load/Eject button to eject any paper in the paper path or advance continuous paper to the tear-off edge. Tear off any continuous sheets and press Load/Eject again to park the continuous paper out of the path.
4. Access the printer software in your application as described in Chapter 1. Change the Ink setting for your document to Black and change any other settings as necessary. Then print the document.

To switch back to color printing, follow the steps beginning on page 6-4 to replace the color ink cartridge. Then turn the printer off and on again to reset color printing mode. Before you print, be sure to set the Ink setting to Color in your printer software as described in Chapters 1 and 2.

Aligning the Print Heads

If your printouts contain misaligned vertical lines, you may need to align the print heads. There are several ways to do this:

- ▶ If you're using a Windows or Macintosh computer connected directly to the printer, you can use the Print Head Alignment utility in your printer software, as described below.
- ▶ If you're printing from DOS, you can use the DOS Print Head Alignment utility. See page 5-7 for instructions.
- ▶ If you're connected to the printer via an optional network interface card or you don't want to use the Print Head Alignment utility, you can use the control panel to align the print heads. See page 6-9 for instructions.

Using the Print Head Alignment Utility

1. Turn on the printer and load paper in the built-in sheet feeder, making sure the right edge guide is positioned correctly for your paper's width and the paper release lever is in the single sheet position. See page 3-6 for instructions.
2. Access the Main printer settings dialog box as described in Chapter 1.
3. Click the Utility tab (Windows) or the Utility button (Macintosh). You see the Utility menu.
4. Click the Print Head Alignment icon.
5. Follow the instructions on the screen to print an alignment test page and select the correct alignment.

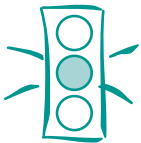

Caution:

Load paper that's at least 8.3 inches (210 mm) wide so ink doesn't spray onto the platen.













Caution:
Load paper that's at least
8.3 inches (210 mm) wide
so ink doesn't spray onto
the platen.

Using the Control Panel

1. Turn on the printer and load paper in the built-in sheet feeder, making sure the right edge guide is positioned correctly for your paper's width and the paper release lever is in the single sheet position. See page 3-6 for instructions.
2. Turn off your printer.
3. Hold down the Pause button and turn on the printer to turn on print head alignment mode.

The printer loads a sheet of paper and prints an instruction sheet telling you how to select a language (the default setting is English). The printer can then print instructions on aligning the print heads in the language you choose.

4. Press the Alt button until the Ink Out  and Ink Out  lights on your control panel indicate the language you want to use.

| | |
|------------|--|
| English | Both lights off |
| French | Ink Out  on and Ink Out  off |
| Spanish | Both lights on |
| Portuguese | Ink Out  flashing and Ink Out  on |
| German | Ink Out  flashing and Ink Out  off |
| Italian | Ink Out  off and Ink Out  on |

5. Press the Pause button. The printer prints instructions on aligning the print heads using the control panel.
6. Follow the instructions on the sheet. When the print heads are aligned, turn off the printer to exit print head alignment mode.
7. After five seconds, turn on the printer to resume printing.

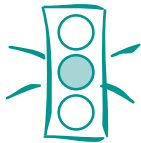

Caution:

Don't touch the gears inside the printer.

Never use alcohol or thinner for cleaning; they can damage the printer components and case.

Don't use a hard or abrasive brush.

Don't get water on the printer components.

Don't spray lubricants or oils inside the printer.

Cleaning the Printer

To keep your printer working at its best, you should clean it several times a year, following these steps:

1. Turn off the printer, unplug the power cord, and disconnect the printer cable.
2. Remove the paper from all the paper feeders.
3. Carefully clean away dust and dirt with a soft, damp cloth.
4. Clean the exterior of the printer with a soft, damp cloth. Keep the printer cover closed so water doesn't get inside.
5. Clean ink out of the printer's interior with a soft, damp cloth.

Transporting the Printer

To move your printer some distance, you need to prepare it for transportation in its original box. Follow these steps:

1. Turn on the printer and wait until the print heads lock in the far right position. Then turn off the printer.
2. Unplug the power cord from the electrical outlet. Then disconnect the interface cable from the printer.
3. Remove the paper from all the feeders. Then remove the paper support, output tray, and cable cover (if installed).
4. Repack the printer and attachments in the original box using the protective materials that came with it. See the Notice Sheet that was packed with the printer.

Be sure to keep the printer level, in an upright position, as you transport it. If print quality declines after transporting the printer, clean the print heads; if output is misaligned, align the print heads. See the instructions in this chapter.



Caution:

To avoid damage, always leave the ink cartridges installed when transporting the printer.

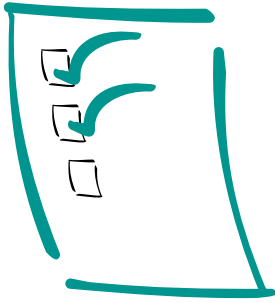

7

Troubleshooting

As you use your printer, you may occasionally experience a paper jam or other problem. The first thing you should do is diagnose the problem following the guidelines in this chapter. Then try the most likely solutions until the problem is fixed.

This chapter tells you everything you need to know about the following:

- Diagnosing problems
- Improving print quality
- Solving printing problems
- Fixing paper jams and other paper problems
- Solving miscellaneous printout problems

Diagnosing Problems

Your printer includes a number of ways to help you diagnose problems:

- To identify the most common problems, check the lights on the printer's control panel. See page 1-13 for instructions.
- You can also use the Status Monitor utility to identify common problems. For instructions, see page 4-4 (Windows 95) or page 4-7 (Macintosh).
- To determine whether the problem is caused by the printer itself, run a printer self test. See the next section for instructions.

- If you're experienced with reading hexadecimal code, you can print a hex dump to identify possible communication problems. See page 7-3 for instructions.
- For the latest information, check the EPSON Stylus COLOR 1520 Help program and the ReadMe file in the EPSON program group or folder.
- If none of the suggested solutions in this chapter solve your problem, contact EPSON as described under "Where to Get Help" in the Introduction.

Running a Self Test

You can run a printer self test to determine whether the problem lies with the printer itself or some other source.

- If the test results are satisfactory, the problem lies in software settings, the interface cable, or your computer.
- If the test pages don't print correctly, you may have a problem with your printer. See the suggestions in this chapter for possible solutions.

Follow these steps to test the printer:

1. Load several sheets of paper in the built-in sheet feeder, making sure the right edge guide is positioned correctly for your paper's width and the paper release lever is in the single sheet position. See page 3-6 for instructions.
2. Turn off the printer.
3. Hold down the Load/Eject button and press the  Operate button to turn on the printer. Then release both buttons. This prints the test pages at 360 dpi. (To print test pages at 180 dpi, hold down the LF/FF button while turning on the printer instead of Load/Eject.)

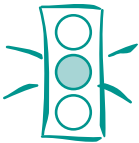

Caution:

Use paper that's at least 8.3 inches (210 mm) wide so ink doesn't spray onto the platen.



Caution:
Never turn off the printer while it's printing test pages. Always press the Pause button and eject any loaded paper first.

The first page prints on the first and last lines to measure the page length. The next page contains a nozzle check pattern and the printer's ROM version, along with multicolored character samples. (The 180 dpi test prints black character samples.)

If the test pages don't print, turn off the printer. Then repeat this step, holding down the Load/Eject button a bit longer before releasing it.

4. After the second page prints, press the Pause button to stop test printing.
5. If the printer loaded any additional paper, press Load/Eject to eject it. Then turn off the printer to end the test.

Printing a Hex Dump

If you're experienced reading hexadecimal code, you can print a hex dump to pinpoint communication problems between your computer and printer. Then you can interpret the code yourself or report the results to a support technician.





Caution:
Use paper that's at least 8.3 inches (210 mm) wide so ink doesn't spray onto the platen.

1. Load several sheets of paper in the built-in sheet feeder, making sure the right edge guide is positioned correctly for your paper's width and the paper release lever is in the single sheet position. See page 3-6 for instructions.
2. Turn off the printer.
3. Hold down the LF/FF and Load/Eject buttons and press the  Operate button to turn on the printer. Then release all the buttons.
4. Open an application and send a print job. The printer prints the data in hexadecimal code.
5. When printing is finished, turn off the printer to exit hexadecimal mode.



Improving Print Quality

You can often improve print quality by doing the following:

- Clean the print heads (see Chapter 6 for instructions).
- Use higher quality paper that's appropriate for your print job (see Chapter 3 for a list of EPSON papers).
- Match the Media Type setting in the printer software to the type of media you loaded in the printer (see Chapter 3 for details).
- Make sure the thickness lever is set to the correct position for your media (see Chapter 3 for details).
- Turn off High Speed mode in the printer software (see Chapter 2 for details).
- Make sure you're not using an Economy option in the printer software (see Chapter 2 for details).
- Replace the ink cartridges. (Check the status of the Ink Out  and Ink Out  lights first. See Chapter 6 for instructions.)

Here are some detailed solutions to specific print quality problems.



Printed image has horizontal banding.

| Possible cause | Solution |
|--|---|
| The Media Type setting doesn't match the loaded paper. | Make sure the Media Type setting matches the loaded paper or other media. Then the printer software can automatically select other settings for the best quality. See Chapters 1 through 3. |
| The printable side of the paper is loaded upside down. | Remove the paper and reload it correctly for the media and feeder you're using. See Chapter 3 for instructions. |
| The print head nozzles are clogged. | Clean the print heads. See Chapter 6 for instructions. |
| The ink cartridges are low on ink. | Check the Ink Out  and Ink Out  lights to see which cartridge you may need to replace. See Chapter 6. |
| The MicroWeave option is not set. | Turn on MicroWeave in the printer software. See Chapter 2 for more information. |

Vertical lines are misaligned or vertical banding appears.



| Possible cause | Solution |
|---|---|
| The print head nozzles are clogged. | Clean the print heads. See Chapter 6 for instructions. |
| High Speed mode or Bi-D mode are turned on. | If vertical lines are misaligned, turn off High Speed mode in the printer software (see Chapter 2 for information). If you're printing with DOS, turn off Bi-D printing using default-setting mode (see Chapter 5 for instructions). |
| The print heads are misaligned. | Run the Print Head Alignment utility. See Chapter 6 for Windows or Macintosh instructions; see Chapter 5 for DOS instructions. |

The printed image has incorrect or missing colors.

| Possible cause | Solution |
|--|--|
| The Ink option is set to Black . | Change the Ink setting to Color . See Chapter 1 for instructions. |
| The Media Type setting doesn't match the loaded paper. | Make sure the Media Type setting matches the paper or media you're using. Then the printer software can automatically select other settings for the best quality. See Chapters 1 through 3. |
| The printable side of the paper is loaded upside down. | Remove the paper and reload it correctly for the media and feeder you're using. See Chapter 3 for instructions. |
| The Halftoning and Color Adjustment Mode options are set incorrectly for your document type. | Use the correct settings for the project you are printing, following the instructions in Chapter 2. |
| The print head nozzles are clogged. | Clean the print heads. See Chapter 6 for instructions. |
| The ICM (Windows 95) or ColorSync (Macintosh) settings are incorrect for your document. | Use the Automatic mode setting or choose a different project type setting. See Chapter 2 for more information. |
| The ink cartridges are low on ink or one or more ink colors are empty. | Check the Ink Out  and Ink Out  lights to see which cartridge you need to replace. See Chapter 6 for instructions. |

| Possible cause | Solution |
|--|---|
| The colors displayed on your monitor don't match the printed colors. | Because your monitor and printer use different technologies to represent colors, your printed colors cannot exactly match those on your monitor screen. Use the ICM (Windows 95) or ColorSync (Macintosh) settings. See Chapter 2 for more information. |
| The color settings in your application software need adjustment. | You may be able to adjust various color settings in your application software. See your software documentation for more information. |

The printed image is faint or has gaps.

| Possible cause | Solution |
|--|--|
| The print head nozzles are clogged. | Clean the print heads. See Chapter 6 for instructions. |
| The Media Type setting doesn't match the loaded paper. | Make sure the Media Type setting matches the loaded paper or other media. Then the printer software can automatically select other settings for the best quality. See Chapters 1 through 3. |
| The loaded paper is upside down, damaged, old, or dirty. | Remove the paper and reload a new stack with the printable side facing correctly. See Chapter 3 for instructions. |
| The ink cartridges are low on ink. | Check the Ink Out  and Ink Out  lights to see which cartridge you need to replace. See Chapter 6 for instructions. |
| You're on a network and the Network I/F setting is turned off. | Try turning on the Network I/F setting using default-setting mode to see if this solves the problem. See Chapter 5 for instructions. |

The printed image is blurry or smeared.

| Possible cause | Solution |
|---|--|
| The printer's thickness lever is in the 0 position. | Set the thickness lever to the + position and try printing again. See Chapter 3 for instructions. |
| The paper is damp or the printable side is upside down. | Remove the paper and reload a new stack with the printable side facing correctly. See Chapter 3 for instructions. |
| You loaded special media without a support sheet. | Follow the special media loading instructions in Chapter 3 and on the paper packaging for media that require support sheets. Also try loading your media one sheet at a time. |
| You tried to print on cardboard or other non-recommended media. | Make sure your paper or media meets the specifications listed in Appendix C. If your printouts are still blurry after you change paper, clean the print heads as described in Chapter 6. |

| Possible cause | Solution |
|--|---|
| The Media Type setting does not match the loaded paper. | Make sure the Media Type setting matches the media you loaded. Then the printer software can automatically select other settings for the best quality. See Chapters 1 through 3 for information. |
| The sheets entering the output tray are smearing the ink on ejected pages. | Remove each sheet from the output tray as soon as it is printed to prevent smearing, especially if you use transparencies. |
| Ink has leaked inside the printer. | Clean carefully inside the printer to remove spilled ink. See Chapter 6 for instructions. |
| The color ink cartridge is empty and you've continued printing with the Ink option set to Color . | Follow the instructions on page 6-7 to print in black ink with an empty color cartridge. Then replace the color ink cartridge following the instructions in Chapter 6. |
| You're using the High Speed (or BiD) and MicroWeave settings with a misaligned print head. | Turn off High Speed mode following the instructions in Chapter 2. (If you're printing with DOS, turn off Bi-D printing in default-setting mode; see Chapter 5.) Then align the print heads following the instructions in Chapter 6 (for Windows and Macintosh) or Chapter 5 (for DOS). |

Photographic images look grainy or rough.

| Possible cause | Solution |
|--|---|
| The print heads are misaligned. | Align the print heads following the instructions in Chapter 6 (for Windows and Macintosh) or Chapter 5 (for DOS). |
| The resolution of your image may be too low. | Increase the image resolution using your image-editing software, or decrease the size of the image. |

Color documents print in black ink only.

| Possible cause | Solution |
|---|--|
| Your printer is not selected in your application. | Select your printer and port in your software application. |
| Color printing is not selected. | Select color printing in your application and the printer software (see Chapter 1). |
| Your color ink cartridge is empty. | Check the Ink Out  light and replace the color cartridge, if necessary. See Chapter 6 for instructions on replacing ink cartridges and printing with an empty color cartridge. |

Solving Printing Problems

If the printer won't print, first check that:

- ▶ The printer is turned on and the Operate light is on.
- ▶ Paper is loaded in the printer.
- ▶ The printer is securely plugged into a working electrical outlet that's not controlled by a switch or timer.
- ▶ The interface cable is securely connected to the printer and computer.

If you still can't print, check the following solutions.

All lights are off.

| Possible cause | Solution |
|-------------------------------------|--|
| The printer is not receiving power. | Turn off the power and plug in the power cord securely, making sure the outlet is not controlled by a switch or timer and is operable. |

Only the Operate light is on, but nothing prints.

| Possible cause | Solution |
|---|--|
| The interface cable is not connected securely. | Turn off your printer and computer. Then make sure the cable is connected securely and meets both the printer and computer specifications. See Appendix C and your computer documentation for information. |
| The printer has an internal problem. | Turn off the printer and computer, disconnect the interface cable, and run a printer self test as described on page 7-1. |
| Your printer or application software is installed incorrectly. | If the self test prints correctly, check your printer and application software for correct installation. If you're printing on a network, make sure you set up your printer as described in Chapter 4. |
| Your computer doesn't have enough memory to handle the data in the file you are printing. | Try one of the following: <ul style="list-style-type: none">▶ Reduce the resolution of your image.▶ Select fewer colors or a lower resolution for your monitor.▶ Add more memory to your computer. |
| Printing is stalled in Spool Manager (Windows 95/3.1) or the Windows NT print queue. | Delete the stalled print jobs in Spool Manager or the Windows NT print queue and resume printing. See Chapter 4 for instructions. |

| Possible cause | Solution |
|---|---|
| Printing is stalled in Monitor2 (Macintosh). | Open the Extensions folder, EPSON folder, and Spool folder. Then delete any queued files. |
| The print heads are clogged or the ink cartridges are too old. | If the printer sounds like it's trying to print but nothing prints, clean the print heads; see Chapter 6 for instructions. If cleaning doesn't help, replace the cartridges. For information on cartridge life and replacement instructions, see Chapter 6. |
| You're using an incompatible optional interface card or one with mismatched settings. | Check the specifications for your interface card and cable, making sure they meet the printer's requirements (see Appendix A) and that they match your computer's settings (see your computer manual). Also try turning on the Network I/F setting in default-setting mode if you're sharing the printer (see Chapter 5). |

The Paper Out *light is flashing or on.*

| Possible cause | Solution |
|---|---|
| If flashing, paper is jammed. | Remove the paper and follow the guidelines for preventing jams on page 7-15. |
| If on, paper is not loaded or is loaded incorrectly, or the paper release lever is set incorrectly. | Load paper, or remove the paper and reload it as described in Chapter 3, making sure to set the paper release lever correctly. Then press the Load/Eject button to turn off the light and resume printing. |

An Ink Out  or Ink Out  light is flashing or on.

| Possible cause | Solution |
|---|--|
| If flashing, the ink supply is getting low. | You need to replace the indicated ink cartridge soon. Make sure you have a new cartridge, then see Chapter 6 for instructions. |
| If on, the ink cartridge is empty. | You must replace the indicated ink cartridge; see Chapter 6 for instructions. |

All the lights come on briefly, then go off.

| Possible cause | Solution |
|--|---|
| The printer's voltage doesn't match your outlet's voltage. | Check the label on the back of your printer to determine its voltage. If it doesn't match your outlet's voltage, turn off the printer and unplug it immediately. Then contact your dealer. Do not plug the printer back in. |

All the lights are flashing.

| Possible cause | Solution |
|--------------------------------------|---|
| An internal error may have occurred. | Turn off your printer, wait five seconds, and turn it on again. If the lights still flash or stay on, contact EPSON as described in the Introduction. |

The printer has finished charging an ink cartridge, but the Pause light is still flashing.

| Possible cause | Solution |
|--|--|
| The ink cartridge clamp isn't locked down. | Press down on the clamp to lock it into place. |
| The printer needs to initialize. | If the printer is not moving or making noise, but the light is still flashing after 10 minutes, turn the printer off. If the light is still flashing when you turn it back on, contact EPSON as described in the Introduction. |

The printer sounds like it's printing but nothing prints.

| Possible cause | Solution |
|-------------------------------------|---|
| The print head nozzles are clogged. | Clean the print heads. See Chapter 6 for instructions. |
| The ink cartridges are too old. | For information on cartridge life and replacement instructions, see Chapter 6. |
| The printer is charging ink. | If you just turned on the printer, it may be charging the ink delivery system, especially if it has been turned off for a while. This can take up to 7 minutes; wait until it finishes before printing. |

The printer software installed with Windows 3.1 does not work correctly after you upgrade to Windows 95.

| Possible cause | Solution |
|--|---|
| Your printer software isn't set up for Windows 95. | Reinstall the printer software after installing Windows 95, as described in the <i>Quick Setup</i> booklet. |

After you install your printing software, you see the Windows 95 New Hardware Found window.

| Possible cause | Solution |
|---|---|
| An operating system error has occurred. | Click Do not install a driver, and then click OK. |

You see a spooling error message (Windows 95/3.1).

| Possible cause | Solution |
|---|--|
| Spooling error messages or very slow printing may be caused by temporary files. | Change the Spool Manager default directory, following the instructions in Chapter 4. |
| Your hard drive is too full. | Delete unnecessary files to make room on the drive. |
| Your computer doesn't have enough memory for the file you're printing. | Try one of the following: <ul style="list-style-type: none"> ▶ Reduce the resolution of your image. ▶ Select fewer colors or a lower resolution for your monitor. ▶ Add more memory to your computer. |

In Windows 95, the Status Monitor box does not appear with the Despooler.

| Possible cause | Solution |
|---|---|
| The Windows Print Manager is interfering with the Status Monitor. | Make sure Use Print Manager for this port is not checked in the Spool Manager Queue setup. See Chapter 4 for instructions. |

A portion of your image doesn't print or you see a memory error message (Macintosh).

| Possible cause | Solution |
|---|--|
| Your system doesn't have enough available memory. | Close any other applications you are running or turn off background printing. |
| You may need to increase the memory allocation for your application, EPSON Monitor2, or both. | Choose Get Info from the File menu when your application is active and increase the memory requirements. See Chapter 4 for more information. Or turn off background printing (you won't be able to use Monitor2). |

Your printer switches to the modem port or won't confirm on the printer port (Macintosh).

| Possible cause | Solution |
|--------------------------------------|---|
| Your system has extension conflicts. | Make sure AppleTalk is inactive. In the Extensions Manager, disable the AppleShare, FileShare, and PrinterShare extensions. Set your printer and any unused printers to the printer port. Then restart your system. |
| You're using an AppleTalk cable. | Make sure you're using a standard Apple System Peripheral-8 cable. See the specifications in Appendix C. |

The “Sorry, EPSON Stylus COLOR cannot be used” message appears (Macintosh).

| Possible cause | Solution |
|--|---|
| The printer software has been corrupted. | Remove and reinstall the printer software. From the CD-ROM or diskette, click Installer . Then click Continue and select Custom Remove from the list displaying Easy Install . Select EPSON Stylus Series Printer Driver and click Remove . Click Continue , if necessary, and click Restart . Then follow the instructions in the <i>Quick Setup</i> booklet to reinstall the printer software and select your printer. Then, in the Extensions Manager, disable Quick Draw GX, enable EPSON Monitor2 and EPSON Stylus Color, and restart your Macintosh. |

Your printer icon doesn't appear in the Chooser (Macintosh).

| Possible cause | Solution |
|--------------------------------------|---|
| Your system has extension conflicts. | In the Extensions Manager, disable Quick Draw GX, enable EPSON Monitor2 and EPSON Stylus Color, and restart your Macintosh. |

Printing is too slow.

| Possible cause | Solution |
|---|---|
| Your printer software options are set incorrectly. | For the fastest printing, try these settings (described in Chapters 1 and 2): <ul style="list-style-type: none">▶ Set Print Quality to Economy.▶ Turn High Speed on.▶ Choose Black ink.▶ Choose No Halftoning. |
| Your system doesn't have enough resources. | <ul style="list-style-type: none">▶ Reduce the resolution of your image.▶ Clear more hard disk space or run a defragmentation utility.▶ Don't run too many applications at the same time.▶ Turn off virtual memory.▶ Increase your system's memory (RAM). |
| You're using background printing on a Macintosh. | Choose Get Info from the File menu when your application is active and increase the memory requirements. See Chapter 4 for more information. Or turn off background printing (you won't be able to use Monitor2). |
| Your Spool Manager settings are incorrect (Windows 95/3.1). | Change your default spool directory and other settings as described in Chapter 4. |

Fixing Paper Problems

You can avoid most paper handling problems by doing the following:

- Use smooth, high-quality media designed for ink jet printers that meet the media specifications in Appendix C.
- Make sure the paper is dry and flat before loading it.
- Follow all loading and handling instructions included with the media and in Chapter 3.

If you have problems with paper feeding, paper jams, or ejected paper, check here for solutions.

Paper doesn't feed correctly from the sheet feeder.

| Try this | Then do this |
|--|---|
| Remove the stack of paper from the sheet feeder. | <p>Check that the paper isn't:</p> <ul style="list-style-type: none"> ● Curled or creased. ● Too thick or thin (see Appendix C). ● Too old (see Chapter 3 or your paper packaging). ● Overloaded in the feeder (see Chapter 3 for guidelines). ● Jammed inside the printer. (If the Paper Out light is flashing, paper is jammed. See page 7-15.) <p>Then reload the paper as described in Chapter 3, making sure that:</p> <ul style="list-style-type: none"> ● The paper release lever is set to the single sheet position. ● The edge guides fit the paper's width snugly, but not too tightly. ● No continuous paper is in the paper path. (Press Load/Eject to park it out of the way.) |

Paper doesn't feed correctly from the manual feeder.

| Try this | Then do this |
|--|--|
| Remove the paper from the manual feeder. | <p>Check that the paper sheet isn't:</p> <ul style="list-style-type: none">• Curled or creased.• Too thick or thin (see Appendix C).• Too old (see Chapter 3 or your paper packaging).• Jammed inside the printer. (If the Paper Out light is flashing, paper is jammed. See page 7-15.) <p>Then reload the paper as described in Chapter 3, making sure that:</p> <ul style="list-style-type: none">• The paper release lever is set to the single sheet position.• The edge guides fit the paper's width snugly, but not too tightly.• The paper is loaded all the way into the printer.• No continuous paper is in the paper path. (Press Load/Eject to park it out of the way.) |

Paper doesn't feed correctly from the tractor feeder.

| Try this | Then do this |
|--|---|
| Remove the continuous paper from the tractor feeder following the instructions on page 3-18. | <p>Check that the paper isn't:</p> <ul style="list-style-type: none">• Curled or creased.• Too thick or thin (see Appendix C).• Too old (see Chapter 3 or your paper packaging).• Jammed inside the printer. (If the Paper Out light is flashing, paper is jammed. See page 7-15.) <p>Then reload the paper as described in Chapter 3, making sure that:</p> <ul style="list-style-type: none">• The paper release lever is set to the continuous paper position.• The paper stack is close enough to the printer, but has room in front and back to load and eject without obstruction.• The paper's holes are aligned on the sprockets, the sprockets are locked and their covers are closed, and the paper is not too slack.• No single sheet paper is in the paper path. (Press Load/Eject to eject any sheets.) <p>Before printing, check that:</p> <ul style="list-style-type: none">• The paper source and paper size are set correctly in your application or printer software. If you're using DOS, check the Page Length setting in default-setting mode (see Chapter 5).• The skip over perforation, auto tear-off, and banner modes are set correctly for your media (see Chapter 5). |

Multiple pages feed at the same time.

| Try this | Then do this |
|----------------------------|---|
| Remove the stack of paper. | <ul style="list-style-type: none"> ▶ Make sure the paper isn't too thin (see the paper specifications in Appendix C). ▶ Fan the edges of the stack of paper to separate the sheets. ▶ Reload the paper as described in Chapter 3, making sure to load only the amount of paper directed for your media and feeder. ▶ If more copies of a page or document are printing than you expected, check that the Copies settings in both the printer software and your application program are set to 1. See Chapters 1 and 2 for information. |

Paper jams inside the printer.

| Try this | Then do this |
|---|---|
| Turn off your printer, open the cover, remove any loaded paper, and remove any little pieces that may have torn off inside. | <p>You may need to turn the knob on the left side of the printer counterclockwise to eject all the torn pieces of paper. Never turn this knob when the printer is on. You'll damage the printer and lose the top-of-form position.</p> <p>Then reload the paper as described in Chapter 3.</p> <p>If your paper jams frequently, make sure you:</p> <ul style="list-style-type: none"> ▶ Use smooth, high-quality paper, with the printable side loaded correctly for your media type and feeder. ▶ Fan the stack and then even the edges before loading it. ▶ Don't load too much paper for your media type and feeder. ▶ Adjust the edge guides or sprockets to fit the width of your paper snugly, but not too tightly. |

Paper doesn't eject fully or is wrinkled.

| Possible cause | Solution |
|--|---|
| If the paper doesn't eject fully, you may have set the wrong paper size. | Press the Load/Eject button to eject the paper. Then make sure you select the correct paper size in your application software, printer software, or default-setting mode. (See the paper specifications in Appendix C for the paper sizes you can print with.) |
| If it's wrinkled when it comes out, the paper may be damp or too thin. | See the paper specifications in Appendix C for paper thicknesses you can print with, as well as environmental requirements for storage. |

Solving Miscellaneous Printout Problems

If your printout results are not what you expected, try these solutions.

Characters are incorrect or garbled.

| Possible cause | Solution |
|---|--|
| Your printer is not the Windows default printer. | Select your printer as the default Windows printer. See your Windows documentation or online help for instructions. |
| Your printer is not selected in the Macintosh Chooser. | Open the Chooser and select your printer. See the <i>Quick Setup</i> booklet for instructions. |
| Your printer is not selected in your DOS applications. | Select printer software for each DOS application you use, as described in Chapter 5. |
| Printing is stalled in Spool Manager (Windows 95/3.1) or in the Windows NT print queue. | Delete the stalled print jobs in Spool Manager or the Windows NT print queue following the instructions in Chapter 4. Then try printing again. |
| If you're using background printing on a Macintosh, spooled data may be corrupted. | Open the Extensions folder, EPSON folder, and Spool folder. Then delete any queued files. Increase the memory requirements for EPSON Monitor2 as described in Chapter 4. |
| The interface cable is not securely connected. | Turn off your printer and computer. Then make sure the cable is connected securely and meets the printer's specifications. |
| You're printing with DOS and your software or default-setting mode settings are incorrect. | If you selected your font, pitch, character table, and line spacing settings in your application software, make sure those settings are correct. If you set them using your printer's default-setting mode (along with the Network I/F setting), follow the instructions in Chapter 5 to make sure those settings are correct. |
| The printer's parallel interface transfer rate doesn't match your computer's transfer rate. | Set the Parallel I/F transfer rate option to Normal using default-setting mode. See Chapter 5 for instructions. |

The margins are incorrect.

| Possible cause | Solution |
|---|--|
| Margins are set incorrectly in your software application. | Check your software documentation for instructions on selecting the correct margins for your paper size. The maximum printable width is 13.6 inches (345 mm) on any size paper. Make sure the margins are within the printable area of the page. See Appendix C for more information. |
| Paper settings in the printer software are incorrect for your paper size. | Select the correct paper settings for your paper size. See Chapters 1 and 2 for more information. |
| The edge guides or sprockets are set incorrectly. | The edge guides or sprockets in the paper feeder are set incorrectly for your paper's width. See the instructions in Chapter 3. You may also need to adjust the margins in your software application to match the new loading position. |

The image is inverted as if viewed in a mirror.

| Possible cause | Solution |
|--|---|
| You used a Flip Horizontal option in your application software or the printer software. | Turn off the Flip Horizontal or mirror setting in your application software or the printer software. See Chapter 2 for information. Remember that images printed on iron-on transfer paper and back light film should be inverted so they appear correctly when transferred or viewed from the reverse side. |

The printer prints blank pages.

| Possible cause | Solution |
|---|---|
| The print head nozzles are clogged. | Clean the print heads following the instructions in Chapter 6. |
| Paper settings in the printer software are incorrect for your paper size. | Select the correct paper settings for your paper size. See Chapters 1 and 2 for more information. |
| Your printer is not the Windows default printer. | Select your printer as the default Windows printer. See your Windows documentation or online help for instructions. |
| Your printer is not selected in the Macintosh Chooser. | Open the Chooser and select your printer. See the <i>Quick Setup</i> booklet for instructions. |

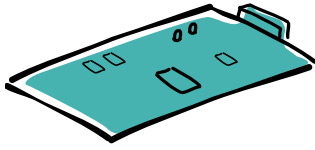

A

Using Optional Interfaces

Your EPSON Stylus COLOR 1520 includes both parallel and serial interfaces so you can connect it to a PC or Macintosh, or both at the same time. If you want to connect to another system or to a network, you can install an optional interface board.

You can install one of the following EPSON interface boards in your printer:

| Type of interface board | Model number | Compatibility |
|-------------------------------|--------------|---------------|
| Serial | C823051 | PC |
| 32KB serial | C832071 | PC |
| 32KB parallel | C823101 | PC |
| Twinax | C823151 | PC |
| Coax | C823141 | PC |
| LocalTalk | C823121 | Macintosh |
| Ethernet | C823461 | Macintosh/PC |
| Type B bidirectional parallel | C823452 | PC |

To order an interface board, contact your dealer or call EPSON Accessories at (800) 873-7766 (U.S. sales only). In Canada, call (800) 873-7766 for dealer referral.

This chapter tells you how to install and use EPSON interface boards in the following sections:

- Using Macintosh interface boards
- Using the PC serial interface board
- Installing optional interfaces

Using Macintosh Interface Boards

If you are planning to install the LocalTalk board, you also need two LocalTalk Locking Connector Kits (DIN-8 version). Attach one connector box to the AppleTalk interface on the printer and the other to the printer port on the Macintosh. Then attach the LocalTalk cable between the two connector boxes. For more information, see the instructions that come with the connector kits.

If you install the Ethernet board connected to a thin coaxial (10BASE2) cable, and the printer is the last device on the network, you need to obtain a 50-ohm terminator. The Ethernet transceiver is included on the EPSON Ethernet board, so you don't need an adapter box for the printer.

Using the PC Serial Interface Board

Before you install the serial interface board in your printer, follow the instructions that come with the board for setting the baud rate and parity. You may also need to set the board's handshake timing, error handling, and other data transfer conventions. Refer to your computer documentation for information about matching the board's settings to your computer system.

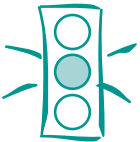

Caution:

To avoid damaging your printer or computer, do not install the interface board when the printer is connected to an electrical outlet.

Installing Optional Interfaces

Before you install an optional interface board in your printer, make sure the printer is turned off and all the printer's lights are off. Then follow these steps:

1. Unplug the power cord from the electrical outlet (and from the back of the printer, if your printer's power cord is removable).

2. Disconnect any interface cables from the back of the printer.
3. Use a Phillips-head screwdriver to remove the two screws securing the interface cover. Then lift off the cover.

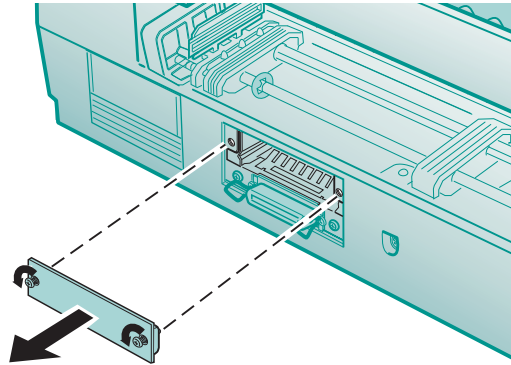

4. Set any switches and jumpers on the interface board as described in its manual. If your board has a jumper labeled JG, make sure that you set it to ON, or the board will not work properly.
5. Slide the interface board along the slots on both sides of the compartment. Push it in firmly to fully insert the board's connector into the printer's internal socket.

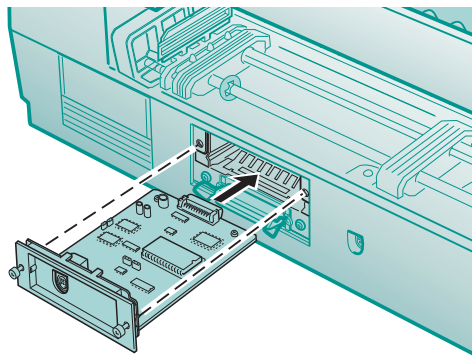

6. Secure the interface board in the slot with the two screws included with the board.

7. Connect the proper interface cable to the interface board and to your computer. If the cable has a grounding wire, connect it to one of the screws securing the interface board.
8. Reconnect any other interface cables you disconnected.
9. Make sure the printer is turned off. Then plug in the power cord and turn on the printer.

In most cases, the printer automatically detects the interface you're using. However, if you have trouble printing through an installed interface board, you may need to change the printer's I/F (interface) mode setting using default-setting mode. See page 5-3 for instructions.

To remove the interface board, first follow steps 1 and 2 in this section. Remove the screws securing the board and carefully pull it out of the internal printer socket. Then replace the interface cover and screws you removed in step 3. Now you can connect your printer using one of the built-in interfaces as described in your *Quick Setup* booklet.



B Using EPSON Plot!

You can use the EPSON Plot! program to open and scale HPGL or HPGL/2 plotter files and then print them on your printer. Follow the instructions in this Appendix to install the program and print with EPSON Plot! and your Windows printer driver.

You can install and use EPSON Plot! on any system running Windows 3.1, Windows 95, or Windows NT (3.51 or 4.0). Make sure to connect the printer to that system and install the printer software following the instructions in the *Quick Setup* booklet before you begin.

Installing EPSON Plot!

Follow these steps to install EPSON Plot! on the system connected to the printer:

1. Make sure Windows is running, but no applications are open.
2. Insert the EPSON Plot! Disk 1 diskette in a drive.
3. With Windows 3.1 or Windows NT 3.51 Program Manager, open the File menu and click Run.

With Windows 95 or Windows NT 4.0, click Start, then click Run.

4. Type A:\SETUP or B:\SETUP and click OK.



Note:
You can also install
EPSON Plot! from the
printer software
CD-ROM.

5. Follow the instructions on the screen to install the program on your hard disk.

The installation program creates an EPSON Plot! program group or folder containing the program icon and icons for Help, Readme, and Uninstall programs.

Printing with EPSON Plot!

Before starting EPSON Plot!, do the following to prepare for printing:

- Install the EPSON Stylus COLOR 1520 Windows printer software on the computer connected to the printer. (See the *Quick Setup* booklet for instructions.)
- Turn on the printer.
- Create an HPGL or HPGL/2 plot file using your plotter software on any system.
- Copy that plot file to the system connected to the printer, if necessary.

Now follow these steps to open EPSON Plot! and print:

1. Double-click the EPSON Plot! icon in the EPSON Plot! program group or folder. You see the following screen:



Note:

When you create plot files for printing, use an HPGL/2 driver whenever possible. HPGL/2 drivers do a better job of maintaining the colors assigned in your CAD application than HPGL drivers, which may limit you to 8 or 16 pen colors.



2. Select Open File from the File menu.
3. In the Open File dialog box, choose the HPGL or HPGL/2 file you want to print and click OK. A representation of the file contents appears in the Live Paper Space in EPSON Plot!



Note:
The gray area around the image represents the area you cannot print on.

If you resize the plot file, EPSON Plot! retains the proportions of the original and preserves the X and Y coordinates.

Keep in mind that the Print Quality (resolution) you select in the printer software may resize your image differently than it is displayed in EPSON Plot!.

4. Select Printer Setup from the File menu.
5. Select the EPSON Stylus COLOR 1520 printer, if necessary, and click Options. You see the Main printer settings menu.
6. Follow the instructions in Chapters 1 and 2 to select the correct printer settings. Make sure to select the Paper Source and Paper Size options for your paper and feeder so EPSON Plot! can display the plot file contents exactly as it will appear when you print.
7. When you're finished selecting your printer software settings, click OK. Then click OK in the Printer Setup dialog box.
8. If you want to resize the plot file, click a handle in the Live Paper Space and drag it to change the size. To reposition the plot, click inside the image display and drag it into position.

9. When the plot file looks how you want it to, select Print from the File menu.
10. Click OK to print the file on your EPSON Stylus COLOR 1520.

See Chapters 1 and 4 for information on managing the print job while it prints.

11. When you're finished printing with EPSON Plot!, select Exit from the File menu to exit the program.



C

Specifications

Printing

Printing method On-demand ink jet

Nozzle configuration Monochrome (black) 128 nozzles
Color (cyan, magenta, yellow) 192 nozzles, 64 of each color

Printable columns and printing speeds

| Character pitch (characters per inch) | Printing column | Draft printing speed | LQ printing speed |
|---------------------------------------|-----------------|----------------------|-------------------|
| 10 | 136 | 800 cps | 400 cps |
| 12 | 163 | 960 cps | 480 cps |
| 15 | 204 | 1200 cps | 600 cps |
| 17 (10 condensed) | 233 | 1378 cps | 684 cps |
| 20 (12 condensed) | 272 | 1600 cps | 800 cps |

cps = characters per second

Resolution Maximum 1440 dpi × 720 dpi

Print direction Bidirectional with logic seeking for text and graphics. (Auto print direction can be set in default-setting mode.)

Control code ESC/P 2 and expanded raster graphics code
IBM XL24E emulation

Line spacing Default is 1/6 inch, programmable in 1/8-inch or 1/360-inch increments

Paper feed speed 107 milliseconds per 1/3-inch line

Input buffer 64KB

Specifications

Fonts

Bitmap fonts

| Font | 10 cpi | 12 cpi | 15 cpi | Proportional |
|------------------|--------|--------|--------|--------------|
| EPSON Roman | x | x | x | x |
| EPSON Sans Serif | x | x | x | x |
| EPSON Courier | x | x | x | — |
| EPSON Prestige | x | x | x | — |
| EPSON Script | x | x | x | — |

Select other font/pitch combinations using the ESC/P 2 commands as described on page 5-17.

Scalable fonts

| Font | Minimum point size | Maximum point size | Increments |
|--------------------|--------------------|--------------------|------------|
| EPSON Roman | 8 | 32 | 2 |
| EPSON Sans Serif | 8 | 32 | 2 |
| EPSON Roman T | 8 | 32 | 2 |
| EPSON Sans Serif H | 8 | 32 | 2 |



Note:

The printer always uses the fonts you selected with your software application. You need to use the printer's internal fonts only if your application doesn't allow you to select fonts.

Character tables

1 italic and 26 graphics character tables

Character sets

14 international character sets and 1 legal character set



Note:

Character tables are selected with default-setting mode (see page 5-3 for instructions) or by using software commands (see page 5-17 for instructions).

Paper

| Paper type | Size | Paper types | Thickness | Weight |
|--------------------------------|--|--|---|--|
| Single sheets | Letter (8.5 × 11 inches) A4 (210 × 297 mm) A5 (148 × 210 mm) Legal (8.5 × 14 inches) Half Letter (5.5 × 8.5 inches) Executive (7.5 × 10 inches) A2 (420 × 594 mm) Super A3/B (13 × 19 inches) A3 (297 × 420 mm) Ledger (11 × 17 inches) US C (17 × 22 inches) B3 (364 × 514 mm) B4 (257 × 364 mm) B5 (182 × 257 mm) | Plain bond paper and special ink jet papers distributed by EPSON | 0.0025 to 0.004 inch (0.065 to 0.11 mm) | Built-in sheet feeder: 17 to 24 lb (64 to 90 g/m ²) Manual feeder: 14 to 24 lb (52 to 90 g/m ²) |
| Continuous paper | Minimum size each sheet: 4 to 16 inches × 4 inches (101.6 to 406.4 × 101.6 mm) | Plain paper | 0.0025 to 0.0039 inch (0.065 to 0.1 mm) | 14 to 22 lb (52 to 82 g/m ²) |
| Transparencies and glossy film | Letter (8.5 × 11 inches) A4 (210 × 297 mm) A6 (105 × 148 mm, glossy film only) Super A3/B (13 × 19 inches, glossy film only) | Transparencies and glossy film distributed by EPSON | 0.005 to 0.006 inch (0.13 to 0.15 mm) | — |
| Glossy paper | Letter (8.5 × 11 inches) A2 (420 × 594 mm) A4 (210 × 297 mm) Super A3/B (13 × 19 inches) | Glossy paper distributed by EPSON | 0.0066 to 0.0070 inch (0.17 to 0.18 mm) | — |
| Self adhesive sheets | A4 (210 × 297 mm) | Self adhesive sheets distributed by EPSON | 0.0079 inch (0.2 mm) maximum | — |
| Envelopes | No. 10 9.5 × 4.1 inches (240 × 104 mm) DL 8.7 × 4.3 inches (220 × 110 mm) C5 6.4 × 9 inches (162 × 229 mm) | Plain bond paper or air mail paper | 0.006 to 0.02 inch (0.16 to 0.52 mm) | 12 to 24 lb (45 to 90 g/m ²) |
| Index cards | A6 (105 × 148 mm) 8 × 10 inches (203 × 254 mm) | Ink jet cards distributed by EPSON | 0.0091 inch (0.23 mm) maximum | 50 lb (188 g/m ²) |
| Roll paper | 8.3 to 17 inches × 49.2 ft (210 to 432 mm × 15 m) | Roll paper distributed by EPSON | 0.003 to 0.004 inch (0.08 to 0.1 mm) | 17 to 22 lb (64 to 82 g/m ²) |
| Back light film | A2 (420 × 594 mm) | Back light film distributed by EPSON | 0.0051 to 0.0055 inch (0.13 to 0.14 mm) | — |

Specifications

| Paper type | Size | Paper types | Thickness | Weight |
|------------------------|--|------------------------------|---|--------|
| Continuous label paper | Minimum size each backing sheet: 4 to 16 inches × 4 inches (101.6 to 406.4 × 101.6 mm) Minimum label size: 2.5 × 0.94 inches (63.5 × 23.9 mm) | Plain continuous label paper | Maximum total thickness: 0.0079 inch (0.2 mm) Maximum label thickness: 0.0047 inch (0.12 mm) | — |



Note:

Since the quality of any particular brand or type of paper may be changed by the manufacturer at any time, EPSON cannot attest to the quality of any non-EPSON brand or type of paper. Always test samples of paper stock before purchasing large quantities or printing large jobs.

Poor quality paper may reduce print quality and cause paper jams and other problems. If you encounter problems, switch to a higher grade of paper.

Ink jet paper, envelopes, glossy film, glossy paper, transparencies, and self adhesive sheets are usable only under these conditions:

Temperature: 59 to 77 °F (15 to 25 °C)

Humidity: 40 to 60% RH

EPSON Photo Quality Glossy Film and Photo Quality Self Adhesive Sheets should be stored under these conditions:

Temperature: 59 to 86 °F (15 to 30 °C)

Humidity: 20 to 60% RH

Printable areas



Note:

The maximum printable width is 13.6 inches (345 mm) regardless of the paper size or feeder you use.

Single sheets and index cards

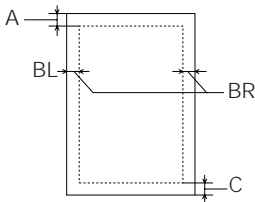

- A: The minimum top margin is 0.12 inch (3.0 mm).
When loading multiple sheets of EPSON Photo Quality Glossy Film, the minimum top margin is 1.2 inches (30 mm).
- BL: The minimum left margin is 0.12 inch (3.0 mm); except for A3 landscape, A2 portrait, Ledger landscape, and US C portrait, which are 0.98 inch (25 mm).
- BR: The minimum right margin is 0.12 inch (3.0 mm); except for A3 landscape and A2 portrait, which are 2 inches (50 mm), and Ledger landscape and US C portrait, which are 2.4 inches (62 mm).
- C: The minimum bottom margin is 0.55 inch (14.0 mm).

Envelopes

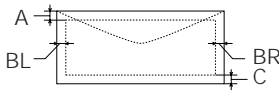

- A: The minimum top margin is 0.12 inch (3.0 mm).
- BL, BR: The minimum left and right margins are 0.12 inch (3.0 mm).
- C: The minimum bottom margin is 0.55 inch (14.0 mm).

Continuous paper

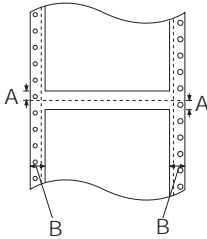

- A: The minimum top and bottom margins above and below the perforations are 0.35 inch (9.0 mm).
- B: The minimum right and left margins are 0.51 inch (13 mm).

Ink Cartridges

| Specification | Black ink cartridge (S020108) | Color ink cartridge (S020089) |
|------------------------|---|--|
| Color(s) | Black | Cyan, Magenta, and Yellow |
| Print capacity* | 900 pages/A4 (ISO/IEC 10561 Letter Pattern at 360 dpi) | 300 pages (A4, 360 dpi, 5% duty each color) |
| Cartridge life | 2 years from production date, if unopened Within 6 months after opening package at 77 °F (25 °C) | |
| Storage temperature | -4 to 104 °F (-20 to 40 °C) 1 month at 104 °F (40 °C) | |
| Transit temperature | -22 to 140 °F (-30 to 60 °C) 1 month at 104 °F (40 °C) 120 hours at 140 °F (60 °C) | |
| Freezing temperature** | 3.2 °F (-16 °C) | -0.4 °F (-18 °C) |
| Dimensions | 1.1 (W) × 2.1(D) × 1.5 (H) inches 27.8 (W) × 52.7(D) × 38.5 (H) mm | 1.7 (W) × 2.1(D) × 1.5 (H) inches 42.9 (W) × 52.7 (D) × 38.5 (H) mm |

* The print capacity may vary, depending on how often you clean the print head.

** It thaws and is usable after approximately 3 hours at 77 °F (25 °C).



Caution:

To ensure good results, use genuine EPSON ink cartridges. Other products may cause damage to your printer not covered by EPSON's warranty.

Don't use an ink cartridge if the date on the package has expired.

Specifications

Mechanical

| | |
|------------------------------|--|
| Paper feed method | Friction, tractor feeder |
| Paper path | Sheet feeder, front entry Manual feeder, rear entry Tractor feeder, rear entry |
| Sheet feeder capacity | 100 sheets of 17 lb (64 g/m ²) paper For detailed information, see Chapter 3. |
| Total print volume | 75,000 pages (A3, text only) |
| Dimensions | |
| Storage | Width: 26.2 inches (666 mm) Depth: 13.1 inches (333 mm) Height: 8.0 inches (202 mm) |
| Printing | Width: 26.2 inches (666 mm) Depth: 24.4 inches (619 mm) Height: 8.0 inches (202 mm) |
| Weight | 33 lb (15 kg) without the ink cartridges |

Electrical

| Specification | 120V Model | 220–240V Model |
|-----------------------|--|----------------|
| Input voltage range | 103.5 to 132V | 198 to 264V |
| Rated frequency range | 50 to 60 Hz | |
| Input frequency range | 49.5 to 60.5 Hz | |
| Rated current | 0.7A | 0.4A |
| Power consumption | Approx. 21W (ISO/IEC 10561 Letter Pattern) | |



Note:
Check the label on the back of the printer for your printer's voltage.

Environmental

| | |
|--------------------|--|
| Temperature | Operation: 50 to 95 °F (10 to 35 °C) Storage: -4 to 140 °F (-20 to 60 °C), stored in shipping container 1 month at 104 °F (40 °C) 120 hours at 140 °F (60 °C) |
| Humidity | Operation: 20 to 80% RH Storage: 5 to 85% RH (stored in shipping container, without condensation) |

Safety Approvals

Safety standards

UL 1950 with D3, CSA C22.2 950 with D3

EMC

FCC part 15 subpart B class B

Interfaces

Parallel interface

Forward channel

Data format: 8-bit parallel, IEEE-1284 compatibility mode

Synchronization: $\overline{\text{STROBE}}$ pulse

Handshake timing: BUSY and $\overline{\text{ACKNLG}}$ signals

Signal level: TTL compatible

Connector: 57-30360 Amphenol connector or equivalent

Reverse channel

Transmission mode: IEEE-1284 Nibble mode

Adaptable connector: 57-30360 Amphenol Connector or equivalent

Synchronization: Refer to the IEEE-1284 specification

Handshaking: Refer to the IEEE-1284 specification

Signal level: IEEE-1284 Level 1 device

Data transmission timing: Refer to the IEEE-1284 specification

Serial interface

Standard: Based on RS-423

Synchronization: Synchronous

Bit rate: Maximum 1.8 Mbps

Handshaking: X-ON/X-OFF, DTR protocol

Word format:

Data bit: 8 bits

Parity bit: None

Start bit: 1 bit

Stop bit: 1 bit

Connector: 8-pin mini-circular connector

Recommended cable: Apple System Peripheral-8 cable (preferably Belkin brand)

Glossary

| | |
|----------------------------------|---|
| banding | The horizontal lines that sometimes appear when printing graphics. See also <i>MicroWeave</i> . |
| buffer | The portion of the printer's memory used to store data before printing it. |
| character table | A collection of letters, numbers, and symbols that provides you with the characters used in a particular language. |
| characters per inch (dpi) | A measure of the size of text characters, sometimes referred to as pitch. |
| CMYK | Cyan (blue-green), magenta, yellow, and black. These colored inks are used to create the subtractive system array of printed colors. |
| ColorSync | Macintosh software that is designed to help you get WYSIWIG (what you see is what you get) output. This software prints colors as you see them on your screen. |
| default | A value or setting that takes effect when the equipment is turned on, reset, or initialized. |
| dithering | A halftoning method in which dots are arranged in an orderly pattern. Dithering works best for printing images with solid colors, such as charts and graphs. See also <i>halftoning</i> . |
| dpi | Dots per inch. The dpi measures the resolution. See also <i>resolution</i> . |
| driver | A software program that sends instructions to a computer device to tell it what to do. For example, your printer driver accepts print data from your word processing application and sends instructions to the printer on how to print this data. |

| | |
|------------------------|--|
| Error Diffusion | This halftoning setting smooths out edges by randomly placing dots of varying colors. |
| ESC/P | Abbreviation for EPSON Standard Code for Printers. This system of commands gives you control of your printer from your computer. It is standard for all EPSON printers and supported by most application programs for personal computers. |
| ESC/P 2 | The enhanced version of the ESC/P printer command language. Commands in this language produce laser-like features, such as scalable fonts and enhanced graphics printing. |
| Finest Detail | This printer driver setting automatically makes your printed images sharper and clearer. Be aware that this may increase the time required for printing. |
| font | A style of type designated by a name. |
| grayscale | A scale of shades of gray from black to white. Grayscale is used to represent colors when printing with black ink only. |
| halftoning | A method of using dot patterns to represent an image. Halftoning makes it possible to produce varying shades of gray using only black dots, or a nearly infinite array of colors using only a few colors of dots. |
| initialization | Returns the printer to its defaults (fixed set of conditions). This happens every time you turn on or reset the printer. |
| ink jet | A method of printing in which each letter or symbol is formed by precisely spraying ink onto paper. |
| interface | The connection between the computer and a peripheral such as a printer. Some printers have two interfaces, parallel and serial. A parallel interface transmits data one byte, or eight bits, at a time. A serial interface transmits data one bit at a time. |
| ips | Inches per second. This scale is used to measure the printing speed. |

| | |
|------------------------------|---|
| media | Materials upon which data is printed, such as envelopes, plain paper, special paper, and transparencies. |
| MicroWeave | Printing technology that produces images in fine increments to reduce the possibility of banding. See also <i>banding</i> . |
| monochrome | This means printing with only one color of ink, which is generally black ink. |
| parallel interface | See <i>interface</i> . |
| print queue | Print jobs that are sent to the printer while it is busy are stored in a waiting line, or print queue, until they can be printed. |
| print server | The computer connected to the printer. It receives the jobs and then distributes them to the assigned printer. It also holds extra print jobs while the printer is busy. See also <i>print queue</i> . |
| printable area | The area of a page on which the printer can print. It is smaller than the physical size of the page due to margins. |
| printer driver | See <i>driver</i> . |
| proportional printing | Printing in which the width of the character varies from character to character. For example, a capital <i>W</i> receives much more space than a lowercase <i>i</i> . The result looks more like a typeset book than a typewritten draft. |
| reset | To return a printer to its defaults either by sending a command, an $\overline{\text{INIT}}$ signal or by turning the printer off and then back on. |
| resolution | The number of dots per inch used to represent an image. |
| RGB | Red, green, and blue. These colors, in phosphors irradiated by the computer monitor's electron gun, are used to create the additive array of screen colors. |
| scalable fonts | Fonts that can be enlarged or reduced. Non-scalable fonts are called bitmap fonts and can't change in size. |
| screen pattern | This feature prints shaded areas as they appear on screen, instead of printing them as halftones. |

- serial interface** *See interface.*
- spool** The process by which the printer driver converts the print data into codes that your printer understands. This data is then sent to the printer directly or to the print server.
- Spool Manager** An EPSON software program that converts print data into codes that your printer understands. *See also spool.*
- Status Monitor** An EPSON software program that displays the printer's status, such as paper out or the amount of ink remaining before printing.
- subtractive colors** Colors produced by pigments that absorb some colors of light and reflect others. *See also CMYK.*

- A**
- Accessories, EPSON, 5
 - Adhesive sheets, *see* Self adhesive sheets
 - Adjusting
 - cut-off position, 3-31
 - loading position, 3-20
 - margins, 3-10, 3-13, 3-19
 - tear-off position, 3-21
 - Advanced mode, 2-1 to 2-3, 2-6
 - Advanced settings
 - custom, 2-4 to 2-13
 - predefined, 2-1 to 2-4
 - AGM setting, 5-6, 5-19
 - Aligning print heads, *see* Print head alignment
 - Assigning name to printer, 4-14
 - Auto
 - CR setting, 5-6
 - I/F wait time, 5-5
 - line feed setting, 5-6
 - tear-off, 3-14, 3-18, 3-21 to 3-22, 5-3, 5-7
 - AutoCAD driver, 1, 5-1
 - Automatic color adjustment, 2-8
 - Automatic mode, 1-3, 1-10, 2-6, 3-5
- B**
- Back light film
 - choosing, 3-3 to 3-4
 - printing on, 3-33 to 3-35
 - specifications, C-3
 - Background printing
 - Macintosh, 1-11, 4-6 to 4-7, 7-12
 - PC, 4-1
 - Banding, 7-4 to 7-5
 - Banner mode, 3-22, 5-3, 5-7
 - Banners
 - choosing paper, 3-3 to 3-4
 - loading roll paper, 3-22 to 3-26
 - paper specifications, C-3
 - printing from Macintosh, 3-29 to 3-30
 - printing from Windows, 3-27 to 3-28
 - removing roll paper, 3-30 to 3-33
 - Basic printing, 1-1 to 1-14
 - Blank pages, 7-17
 - Blurry printouts, 7-6 to 7-7
 - Brightness setting, 2-9
 - Built-in sheet feeder, *see* Sheet feeder
 - Buttons, control panel, 1-13 to 1-14
- C**
- Cable cover, 3-15
 - Cancelling changes, printer software, 1-4, 1-9
 - Canvas cloth, *see* Ink Jet Canvas Cloth
 - Cards, *see* Ink jet cards
 - Character tables, 5-6, 5-8 to 5-17, C-2
 - Characters, incorrect or garbled, 7-16
 - Cleaning
 - print heads, 6-1 to 6-4, 7-4
 - printer, 6-10
 - sheet, special media, 3-5
 - Coarse Dithering option, 2-6
 - Coax interface board, A-1
 - Collate setting, 1-4
 - Color
 - Adjustment modes, 2-8
 - characteristics, 2-9
 - problems, 7-5 to 7-6

Colorimetric setting, 2-11
ColorSync, 2-3, 2-7, 2-10 to 2-11
Commands, printer, 5-17 to 5-19
Communication problems,
7-2 to 7-3
CompuServe, 6
Continuous paper
choosing settings for, 3-3 to 3-5
printing on, 3-14 to 3-17
removing, 3-18 to 3-19
specifications, C-3 to C-5
switching to single sheets,
3-21 to 3-22
Contrast setting, 2-9
Control codes, 5-17 to 5-19, C-1
Control panel
buttons, 1-13 to 1-14
default-setting mode,
5-3 to 5-7, 7-16, C-2
lights, 1-13 to 1-14, 7-1,
7-8 to 7-10
print head alignment, 6-9
print head cleaning, 6-3
using, 1-13 to 1-14, 7-1
Control Panels, Macintosh, 2-10
Current Settings box, 1-4, 1-11,
2-4
Custom paper size, 3-28 to 3-30
Custom settings
color, 2-7 to 2-10
deleting, 2-12
print quality, 2-4 to 2-7
printing with, 2-1 to 2-13
project types, 2-3, 3-5
redefining, 2-13
saving, 2-11 to 2-12
special effects, 2-4 to 2-7
Customer Care Centers, EPSON,
5
Cut-off position, 3-31
Cyan setting, 2-9

D Default printer options, setting,
1-5 to 1-6
Default-setting mode, 5-3 to 5-7,
7-16, C-2
Despooler, 1-4, 1-7 to 1-8, 4-5
Dithering options, 2-6
DOS
AutoCAD driver, 1, 5-1
changing printer settings,
5-3 to 5-7
character tables, 5-6,
5-8 to 5-17, C-2
EPCALIB utility, 5-7 to 5-8
maintaining printer, 5-7 to 5-8
printer commands,
5-17 to 5-19
selecting printer software for,
5-1 to 5-2
using printer with, 5-1 to 5-19
Download Service, EPSON, 6
Draft printing, 2-3, 2-5

E Economy settings, 2-3, 2-5, 7-4
Electrical specifications, C-6
Electronic support services,
EPSON, 5 to 6
Empty color ink cartridge, printing
with, 6-7, 7-7
Emulation, 5-6, 5-17 to 5-19
ENERGY STAR, 7
Energy-saving tips, 7
Envelopes
printing on, 3-3 to 3-5, 3-9,
3-13
specifications, C-3 to C-4
Environmental specifications, C-4,
C-6
EPCALIB utility, 5-7 to 5-8

- EPSON
 Accessories, 5
 Customer Care Centers, 5
 Download Service, 6
 Electronic support services,
 5 to 6
 FaxAdvice, 6
 help, 5 to 6
 media, 3-2 to 3-4
 World Wide Web site, 6
 EPSON Namer utility, 4-14
 EPSON Plot! utility, 1, B-1 to B-4
 Error Diffusion option, 2-6
 ESC (^ command, 5-17 to 5-18
 ESC R command, 5-16 to 5-18
 ESC/P 2, 5-1, 5-6, 5-16 to 5-18
 Ethernet board, A-1 to A-2
 Extension module, Power
 Macintosh, 1-11
- F**
 Faint printouts, 7-6
 FaxAdvice, EPSON, 6
 Film, *see* Photo Quality Glossy
 media
 Fine Dithering option, 2-6
 Finest Detail setting, 2-6
 Flip Horizontal setting, 2-6, 3-4,
 3-34, 7-17
 Fonts, 5-5, C-2
- G**
 Garbled characters, 7-16
 Glossy media
 choosing, 3-2 to 3-4
 printing on, 3-5
 specifications, C-3 to C-4
 Graph project type, 2-3
- H**
 Halftoning setting, 2-6
 Hard drive space, 2 to 3
 Head Cleaning utility, 6-2
 Help
 EPSON, 5 to 6
 online, 1-11 to 1-12
- Hex dump, printing, 7-2 to 7-3
 High Quality Ink Jet Paper
 choosing, 3-2 to 3-4
 printing on, 3-5
 specifications, C-3 to C-4
 High Speed setting, 2-6, 7-4 to 7-5
 Horizontal banding, 7-4
 HPGL files, printing, B-1 to B-4
 Humidity, C-4, C-6
- I**
 I/F mode, 5-5, A-4
 IBM XL24E emulation, 5-6, 5-19
 ICM (Image Color Matching), 2-3,
 2-7 to 2-10
 Improving print quality, 7-4 to 7-7
 Incorrect
 characters, 7-16
 margins, 7-17
 Index cards, *see* Ink jet cards
 Ink
 monitoring level, 1-7 to 1-8,
 4-5, 4-8
 setting, 1-3, 1-11, 2-2, 2-5, 6-7
 Ink cartridge
 printing with empty color, 6-7
 problems, 7-4, 7-7, 7-9 to 7-10
 replacing, 6-4 to 6-7, 7-4
 specifications, C-5
 Ink Jet Back Light Film
 choosing, 3-3 to 3-4
 printing on, 3-33 to 3-35
 specifications, C-3
 Ink Jet Canvas Cloth
 choosing, 3-3 to 3-4
 printing on, 3-22 to 3-30
 removing, 3-30 to 3-33
 specifications, C-3
 Ink jet cards
 choosing, 3-2 to 3-4
 printing on, 3-10
 specifications, C-3 to C-4
 Ink jet paper
 choosing, 3-2 to 3-4
 printing on, 3-5
 specifications, C-3 to C-4

Ink Jet Transparencies
 choosing, 3-2 to 3-4
 printing on, 3-5
 specifications, C-3 to C-4
Input buffer, C-1
Interface (I/F) mode, 5-5, A-4
Interface boards
 installing, A-2 to A-4
 Macintosh, A-1 to A-2
 parallel, A-1
 problems, 7-9
 removing, A-4
 serial, A-1 to A-2
 using, A-1 to A-4
Interface specifications, C-7
International character sets, 5-6,
 5-16, C-2
Iron-On Transfer Paper
 choosing, 3-2 to 3-4
 printing on, 2-6, 3-4
Italic character set, 5-15

J Jammed paper, 1-13, 7-9, 7-15

K Knob, printer, 3-20, 7-15

L Labels, 3-3, 3-14, 3-18 to 3-21, C-4
 see also Self adhesive sheets
Landscape setting, 1-4, 1-9
Language, selecting, 5-3 to 5-4, 6-9
Legal-size paper, 3-6
Letterhead, 3-5
Lights, control panel, 1-13 to 1-14,
 7-1, 7-8 to 7-10
Line spacing, C-1
Loading position, adjusting, 3-20
LocalTalk board, A-1 to A-2

M Macintosh
 background printing, 1-11,
 4-6 to 4-7, 7-12
 ColorSync, 2-3, 2-7,
 2-10 to 2-11
 Control Panels, 2-10
 interface boards, A-1 to A-2
 interface specifications, C-7
 managing print jobs from,
 4-6 to 4-8
 network printing, 4-13 to 4-15
 online help, 1-12
 printing from, 1-9 to 1-11
Magenta setting, 2-9
Maintaining printer, 6-1 to 6-10
Managing print jobs
 Macintosh, 4-6 to 4-8
 Windows 3.1 or 95, 1-7,
 4-1 to 4-5
 Windows NT, 1-8, 4-5
Manual feeder, 3-11 to 3-13, 7-14
Manuals, how to use, 3 to 4
Margins
 adjusting, 3-10, 3-13, 3-19
 problems, 7-17
 specifications, C-4 to C-5
 with multiple sheets, 3-4
Mechanical specifications, C-6
Media Type setting, 1-3, 1-10, 2-3,
 2-5 to 2-6, 3-3 to 3-5
Media, *see* Paper or specific media
 name
Memory, 2, 7-11
Messenger service, Windows NT,
 1-8, 4-5
Micro Adjust buttons,
 3-20 to 3-21, 5-4
MicroWeave setting, 2-6, 7-4
Mirror images, 2-6, 3-4, 3-33, 7-17
Monitor2 utility, 4-6 to 4-7, 7-9,
 7-16
Monitoring ink level, 4-5, 4-8
More Settings dialog box,
 2-4 to 2-11, 3-5
Moving printer, 6-10

- N**
- Namer utility, EPSON, 4-14
 - Network I/F mode, 5-6, 7-6
 - Network path, 4-12 to 4-13
 - Network printing
 - Macintosh, 4-13 to 4-15
 - PC, 4-9 to 4-13
 - New Hardware Found window, 7-10
 - No Color Adjustment option, 2-9
 - No Halftoning option, 2-6
 - Nozzle Check utility, 6-2 to 6-4
- O**
- Online help, printer software, 1-11 to 1-12
 - Optional interfaces, using, A-1 to A-4
 - Orientation settings, 1-4, 1-9
- P**
- Page length setting, 5-6
 - Page Setup dialog box, 1-9, 3-29
 - Paper
 - choosing, 3-2 to 3-4
 - cleaning sheet, 3-5
 - feed speed, C-1
 - handling problems, 7-13 to 7-15
 - jams, 1-13, 7-9, 7-15
 - legal, 3-6
 - letterhead, 3-5
 - menu, 1-3 to 1-4, 1-9, 3-27
 - plain, 3-3
 - special, printing on, 3-1 to 3-35
 - specifications, C-3 to C-5
 - thickness lever, 3-7, 3-11
 - thickness, *see* Thickness lever
 - Paper release lever, 3-6, 3-11, 3-14, 3-22
 - Paper Size setting, 1-4, 1-9, 2-3, B-3
 - Paper size, custom, 3-28 to 3-30
 - Paper Source setting, 1-4, 1-9, 2-3, B-3
 - Parallel I/F transfer rate setting, 5-7
 - Parallel interface boards, A-1
 - PC serial interface board, A-1 to A-2
 - Perceptual setting, 2-11
 - Photo Quality Banner Paper, *see* Banners
 - Photo Quality Glossy media
 - choosing, 3-2 to 3-4
 - printing on, 3-5
 - specifications, C-3 to C-4
 - Photo Quality Ink Jet media
 - choosing, 3-2 to 3-4
 - printing on, 3-5
 - specifications, C-3 to C-4
 - Photo setting, 2-3
 - Photo-realistic color adjustment, 2-8
 - Pitch, 5-5
 - Plot files, printing, 1, 5-1, B-1 to B-4
 - Portrait setting, 1-4, 1-9
 - Power Macintosh Extension module, 1-11
 - Predefined advanced settings, 2-1 to 2-4
 - Print direction, 5-5, 5-7, C-1
 - Print head alignment
 - control panel, 6-9
 - DOS utility, 5-7 to 5-8
 - problems, 7-5
 - utility, 6-8
 - Print head cleaning, 6-1 to 6-4, 7-4
 - Print jobs, managing
 - Macintosh, 4-6 to 4-8
 - Windows 3.1 or 95, 1-7, 4-1 to 4-5
 - Windows NT, 1-8, 4-5
 - Print quality problems, 7-4 to 7-7
 - Print Quality setting, 2-4 to 2-6
 - Print Using a Temporary File setting, 2-7
 - Printable
 - area, 3-6, 3-16, C-4 to C-5
 - columns, C-1
 - Printer
 - cleaning, 6-10
 - commands, 5-17 to 5-19
 - test, 7-1 to 7-3
 - transporting, 6-10

- Printer software, accessing
 - DOS, 5-1 to 5-2
 - Macintosh applications, 1-9 to 1-11
 - Windows applications, 1-2 to 1-4
 - Windows default, 1-5 to 1-6
- Printer software, using, 1,
 - 1-1 to 1-12, 2-1 to 2-13,
 - 3-3 to 3-5, 5-1
- Printer status
 - Macintosh, 4-6 to 4-8
 - Windows, 1-7 to 1-8, 4-4 to 4-5
- Printing specifications, C-1 to C-2
- Problems
 - communication, 7-2 to 7-3
 - diagnosing, 7-1 to 7-3
 - paper handling, 7-13 to 7-15
 - print quality, 7-4 to 7-7
 - printing, 7-8 to 7-12
 - solving, 7-1 to 7-17
 - unexpected printout results, 7-16 to 7-17

Q Quality/Speed slider, 1-3, 1-11, 2-2

- R** Rendering Intent setting, 2-11
- Replacing ink cartridges, 6-4 to 6-7, 7-4
- Resolution, 2-5, C-1
- Reverse Order setting, 1-4
- Roll paper
 - choosing, 3-3 to 3-4
 - printing on, 3-22 to 3-33
 - specifications, C-3

- S** Safety
 - approvals, C-7
 - instructions, 7 to 9
- Saturation settings, 2-9, 2-11

- Self adhesive sheets
 - choosing, 3-3 to 3-4
 - printing on, 3-5
 - specifications, C-3 to C-4
- Self test, 7-1 to 7-3
- Serial interface boards, A-1 to A-2
- Service, 5 to 6
- Sheet feeder, 3-6 to 3-10, 7-13
- Single sheets
 - loading in manual feeder, 3-11 to 3-13
 - loading in sheet feeder, 3-6 to 3-10
 - printing on, 3-6 to 3-13
 - specifications, C-3 to C-4
 - switching to continuous paper, 3-21 to 3-22
- Skip over perforation, 5-6
- Slashed zero, 5-3, 5-6
- Smear printouts, 7-6 to 7-7
- Software, *see* Printer software,
 - accessing *or* Printer software, using
- Special effects settings, 2-4 to 2-7
- Specifications
 - electrical, C-6
 - environmental, C-6
 - ink cartridge, C-5
 - interface, C-7
 - mechanical, C-6
 - paper, C-3 to C-5
 - printing, C-1 to C-2
- Spool directory, 4-3 to 4-4
- Spool Manager
 - problems, 7-8, 7-11 to 7-12, 7-16
 - using, 4-2 to 4-4
- Status Monitor
 - Macintosh, 4-7 to 4-8
 - problems, 7-1, 7-11
 - Windows, 1-7 to 1-8, 4-4 to 4-5
- Support, EPSON, 5 to 6
- System requirements, 2 to 3

- T**
- Tear off position
 - adjusting, 3-21
 - auto tear-off, 3-14, 3-18, 3-21 to 3-22, 5-3, 5-7
 - Technical specifications, C-1 to C-7
 - Temperature, C-4, C-6
 - Temporary files
 - print using, setting, 2-7
 - problems with, 4-3 to 4-4
 - Testing the printer, 7-1 to 7-3
 - Text/Graph setting, 2-3
 - Thickness lever, 3-7, 3-11, 7-4
 - Thickness setting, adjusting, 3-7, 3-11, 7-4
 - Tractor feeder, 3-14 to 3-19, 7-14
 - Transfer paper, *see* Iron-On Transfer Paper
 - Transparencies
 - choosing, 3-2 to 3-4
 - printing on, 3-5
 - specifications, C-3 to C-4
 - Transporting printer, 6-10
 - Troubleshooting, 7-1 to 7-17
 - Twinax interface board, A-1
- U**
- User Defined paper size, 3-28 to 3-30
 - Utilities
 - EPSON Namer, 4-14
 - EPSON Plot!, 1, B-1 to B-4
 - Head Cleaning, 6-2
 - Monitor2, 4-6 to 4-7, 7-9, 7-16
 - Nozzle Check, 6-2 to 6-4
 - Print Head Alignment, *see* Print head alignment
 - Status Monitor, *see* Status Monitor
- V**
- Vertical banding, 7-5
 - Vertical lines, misaligned, 2-6, 5-7, 7-5
 - see also* Print head alignment
 - Video/Digital Camera setting, 2-3, 2-9
 - Vivid color adjustment, 2-8
 - Voltage, 7-9
- W**
- What's This? prompt, 1-2, 1-12
 - Windows
 - checking printer status, 1-7
 - managing print jobs from, 1-7 to 1-8, 4-1 to 4-5
 - network printing, 4-9, 4-11 to 4-13
 - online help, 1-11 to 1-12
 - printing from, 1-1 to 1-8
 - setting default options, 1-5
 - Windows NT
 - checking printer status, 1-8
 - connecting to printer, 4-9 to 4-10
 - managing print jobs from, 1-8, 4-5
 - online help, 1-12
 - Print Using a Temporary File setting, 2-7
 - printing from, 1-1 to 1-6
 - printing problems, 7-8
 - setting default options, 1-6
 - World Wide Web site, EPSON, 6
- X**
- XL24E emulation, IBM, 5-6, 5-19
- Y**
- Yellow setting, 2-9
- Z**
- Zero setting, 5-3, 5-6